

STANLEY®

FATMAX®

V20

LITHIUM ION

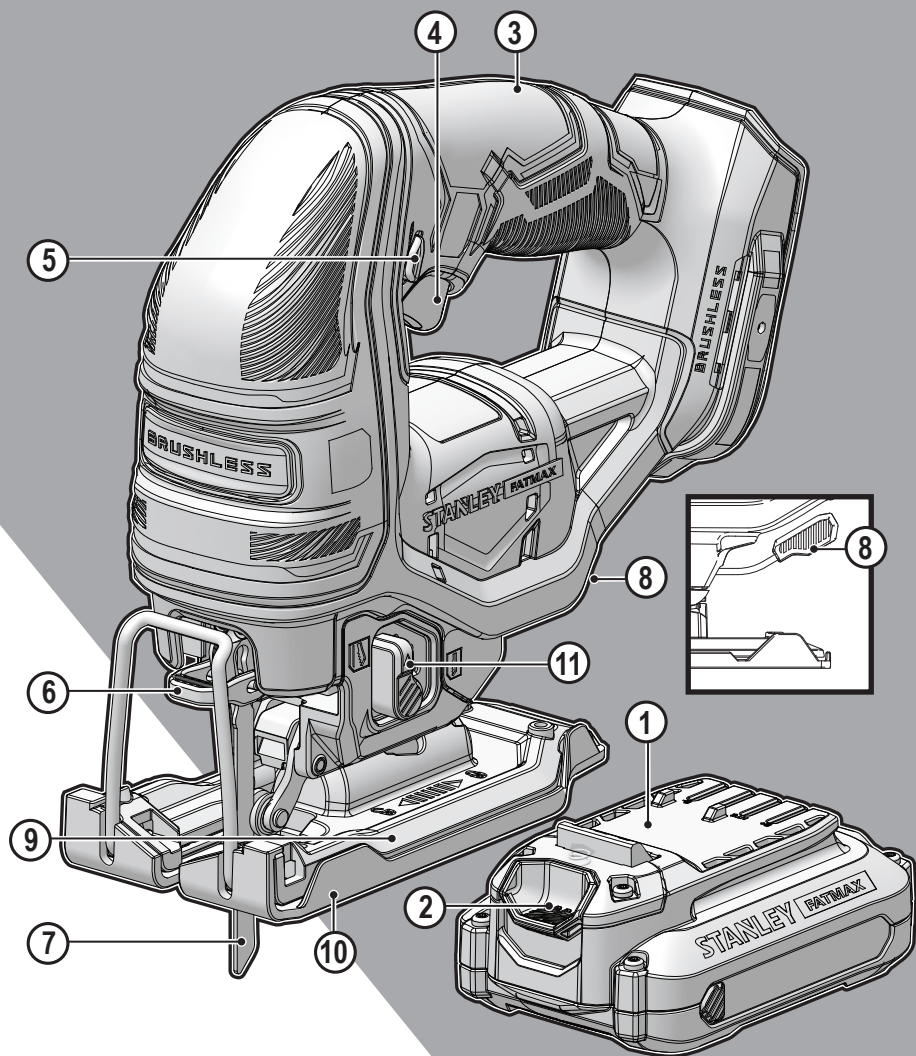

www.stanley.eu

SFMCS650

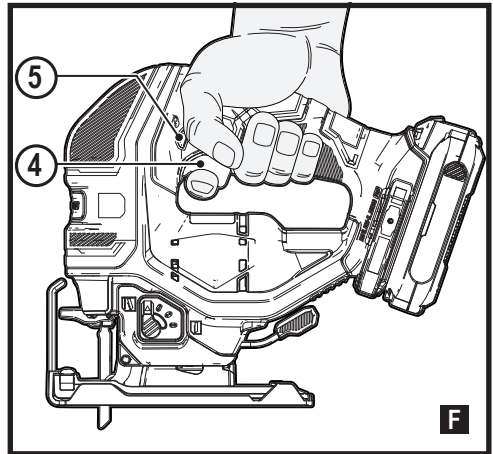
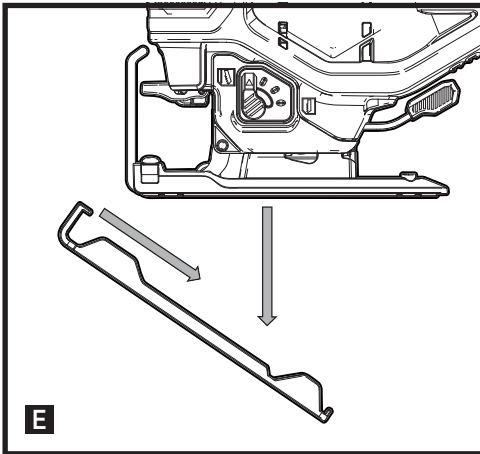
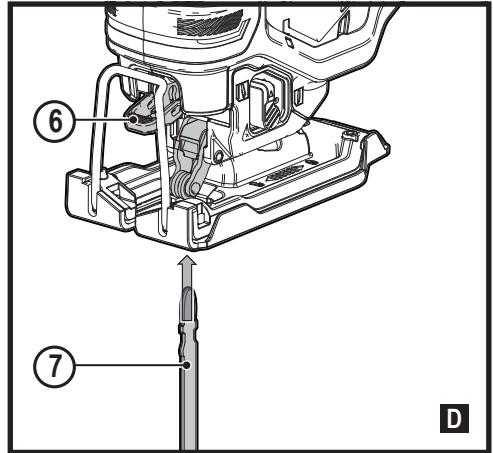
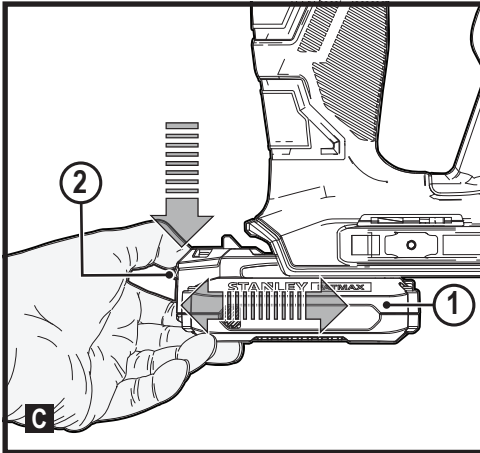
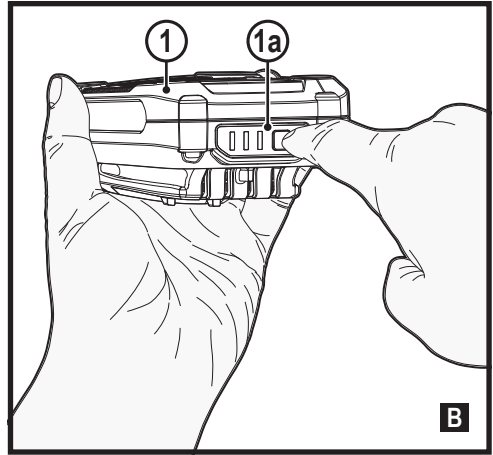
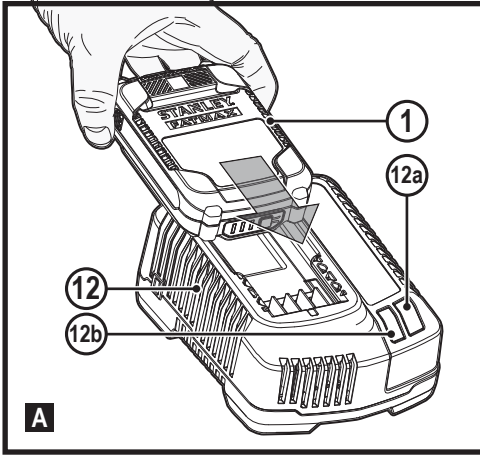

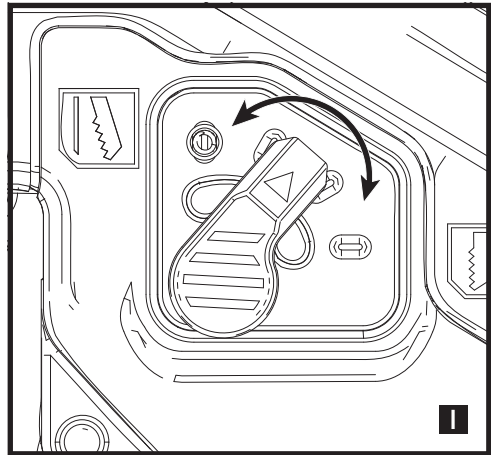
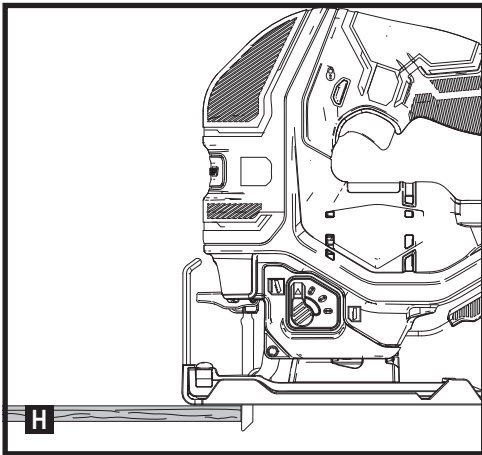
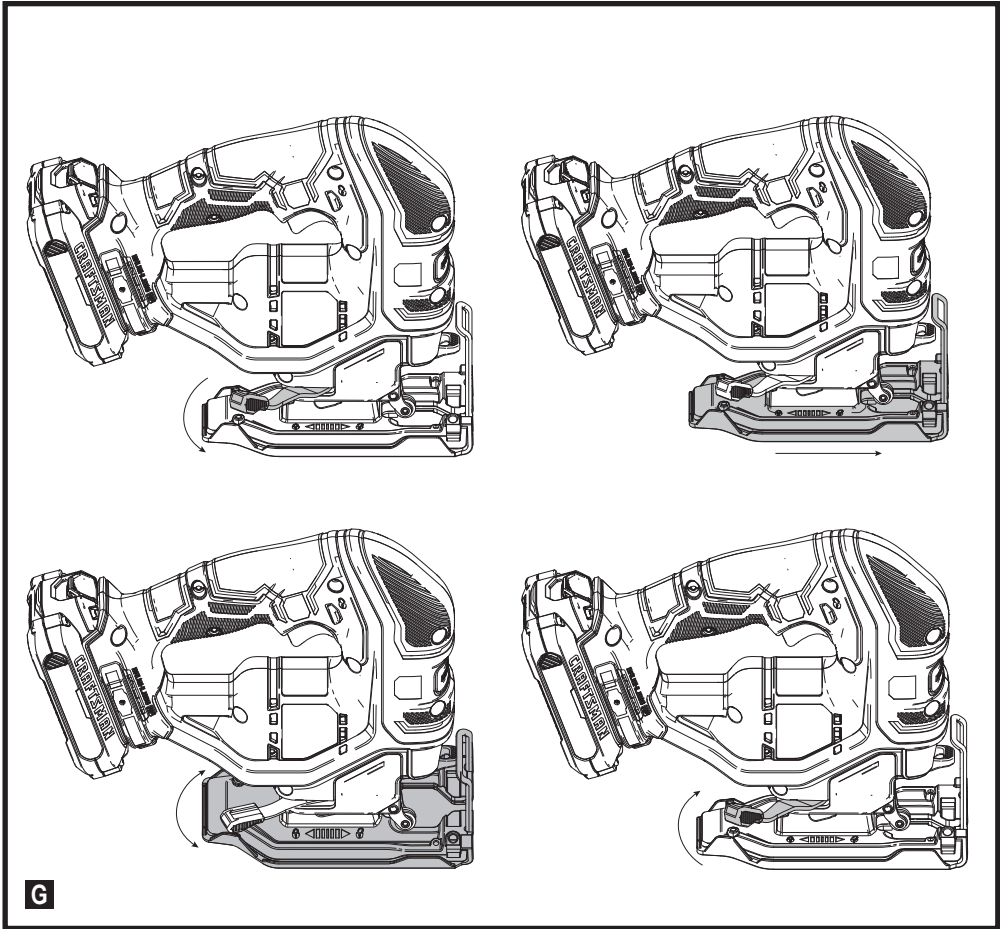

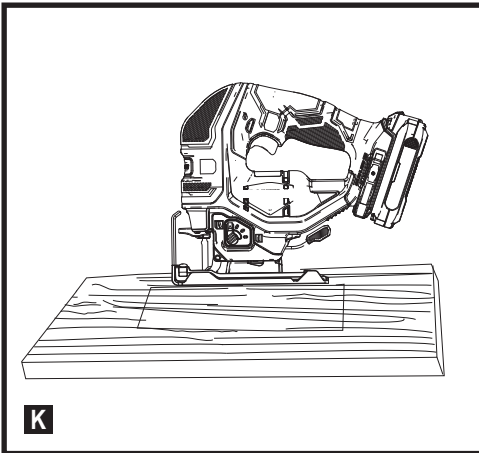
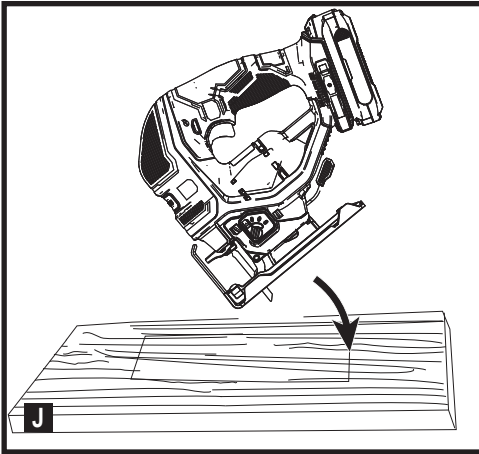

1. Work area safety

- a. **Keep work area clean and well lit.** Cluttered or dark areas invite accidents.
- b. **Do not operate power tools in explosive atmospheres, such as in the presence of flammable liquids, gases or dust.** Power tools create sparks which may ignite the dust or fumes.
- c. **Keep children and bystanders away while operating a power tool.** Distractions can cause you to lose control.

2. Electrical safety

- a. **Power tool plugs must match the outlet. Never modify the plug in any way.**
Do not use any adapter plugs with earthed (grounded) power tools. Unmodified plugs and matching outlets will reduce risk of electric shock.
- b. **Avoid body contact with earthed or grounded surfaces such as pipes, radiators, ranges and refrigerators.** There is an increased risk of electric shock if your body is earthed or grounded.
- c. **Do not expose power tools to rain or wet conditions.** Water entering a power tool will increase the risk of electric shock.
- d. **Do not abuse the cord. Never use the cord for carrying, pulling or unplugging the power tool.** Keep cord away from heat, oil, sharp edges or moving parts. Damaged or entangled cords increase the risk of electric shock.
- e. **When operating a power tool outdoors, use an extension cord suitable for outdoor use.** Use of a cord suitable for outdoor use reduces the risk of electric shock.
- f. **If operating a power tool in a damp location is unavoidable, use a residual current device (RCD) protected supply.** Use of an RCD reduces the risk of electric shock.

3. Personal safety

- a. **Stay alert, watch what you are doing and use common sense when operating a power tool.** Do not use a power tool while you are tired or under the influence of drugs, alcohol or medication. A moment of inattention while operating power tools may result in serious personal injury.
- b. **Use personal protective equipment. Always wear eye protection.** Protective equipment such as dust mask, non-skid safety shoes, hard hat, or hearing protection used for appropriate conditions will reduce personal injuries.
- c. **Prevent unintentional starting. Ensure the switch is in the off-position before connecting to power source and/or battery pack, picking up or carrying the tool.**

Intended use

Your STANLEY FATMAX SFMCS650 jigsaw has been designed for sawing wood, plastics and sheet metal. This tool is intended for professional and private, non professional users.

General power tool safety warnings



Warning! Read all safety warnings, instructions, illustrations and specifications provided with this power tool. Failure to follow all instructions listed below may result in electric shock, fire and/or serious injury.

Save all warnings and instructions for future reference.

The term "power tool" in the warnings refers to your mains-operated (corded) power tool or battery-operated (cordless) power tool.

Carrying power tools with your finger on the switch or energising power tools that have the switch on invites accidents.

- d. **Remove any adjusting key or wrench before turning the power tool on.** A wrench or a key left attached to a rotating part of the power tool may result in personal injury.
- e. **Do not overreach. Keep proper footing and balance at all times.** This enables better control of the power tool in unexpected situations.
- f. **Dress properly. Do not wear loose clothing or jewellery. Keep your hair and clothing away from moving parts.** Loose clothes, jewellery or long hair can be caught in moving parts.
- g. **If devices are provided for the connection of dust extraction and collection facilities, ensure these are connected and properly used.** Use of dust collection can reduce dust-related hazards.
- h. **Do not let familiarity gained from frequent use of tools allow you to become complacent and ignore tool safety principles.** A careless action can cause severe injury within a fraction of a second.

4. Power tool use and care

- a. **Do not force the power tool. Use the correct power tool for your application.**

The correct power tool will do the job better and safer at the rate for which it was designed.

- b. **Do not use the power tool if the switch does not turn it on and off.** Any power tool that cannot be controlled with the switch is dangerous and must be repaired.
- c. **Disconnect the plug from the power source and/or remove the battery pack, if detachable, from the power tool before making any adjustments, changing accessories, or storing power tools.** Such preventive safety measures reduce the risk of starting the power tool accidentally.
- d. **Store idle power tools out of the reach of children and do not allow persons unfamiliar with the power tool or these instructions to operate the power tool.** Power tools are dangerous in the hands of untrained users.
- e. **Maintain power tools and accessories. Check for misalignment or binding of moving parts, breakage of parts and any other condition that may affect the power tools operation. If damaged, have the power tool repaired before use.** Many accidents are caused by poorly maintained power tools.
- f. **Keep cutting tools sharp and clean.** Properly maintained cutting tools with sharp cutting edges are less likely to bind and are easier to control.

- g. **Use the power tool, accessories and tool bits etc. in accordance with these instructions, taking into account the working conditions and the work to be performed.**

Use of the power tool for operations different from those intended could result in a hazardous situation.

- h. **Keep handles and grasping surfaces dry, clean and free from oil and grease.** Slippery handles and grasping surfaces do not allow for safe handling and control of the tool in unexpected situations.

5. Battery tool use and care

- a. **Recharge only with the charger specified by the manufacturer.** A charger that is suitable for one type of battery pack may create a risk of fire when used with another battery pack.

- b. **Use power tools only with specifically designated battery packs.** Use of any other battery packs may create a risk of injury and fire.

- c. **When battery pack is not in use, keep it away from other metal objects, like paper clips, coins, keys, nails, screws, or other small metal objects, that can make a connection from one terminal to another.** Shorting the battery terminals together may cause burns or a fire.

- d. **Under abusive conditions, liquid may be ejected from the battery; avoid contact. If contact accidentally occurs, flush with water. If liquid contacts eyes, additionally seek medical help.** Liquid ejected from the battery may cause irritation or burns.

- e. **Do not use a battery pack or tool that is damaged or modified.** Damaged or modified batteries may exhibit unpredictable behaviour resulting in fire, explosion or risk of injury.

- f. **Do not expose a battery pack or tool to fire or excessive temperature.** Exposure to fire or temperature above 130 °C may cause explosion.

- g. **Follow all charging instructions and do not charge the battery pack or tool outside the temperature range specified in the instructions.** Charging improperly or at temperatures outside the specified range may damage the battery and increase the risk of fire.

6. Service

- a. **Have your power tool serviced by a qualified repair person using only identical replacement parts.**

This will ensure that the safety of the power tool is maintained

- b. **Never service damaged battery packs.** Service of battery packs should only be performed by the manufacturer or authorized service providers.

Additional power tool safety warnings



Warning! Additional safety warnings for jigsaws and reciprocating saws

- ◆ **Hold the power tool by insulated gripping surfaces, when performing an operation where the cutting accessory may contact hidden wiring.** Cutting accessory contacting a "live" wire may make exposed metal parts of the power tool "live" and could give the operator an electric shock.
- ◆ **Use clamps or another practical way to secure and support the workpiece to a stable platform.** Holding the work by hand or against your body leaves it unstable and may lead to loss of control.
- ◆ **Keep hands away from cutting area.** Never reach underneath the work piece any reason. Do not insert fingers or thumb into the vicinity of the reciprocating blade and blade clamp. Do not stabilize the saw by gripping the shoe.
- ◆ **Keep blades sharp.** Dull or damaged blades may cause the saw to swerve or stall under pressure. Always use the appropriate type of saw blade for the workpiece material and type of cut.
- ◆ **When cutting pipe or conduit, make sure that they are free from water, electrical wiring, etc.**
- ◆ **Do not touch the workpiece or the blade immediately after operating the tool.** They can become very hot.
- ◆ **Be aware of hidden hazards, before cutting into walls, floors or ceilings, check for the location of wiring and pipes.**
- ◆ **The blade will continue to move after releasing the switch.** Always switch the tool off and wait for the saw blade to come to a complete standstill before putting the tool down.

Warning! Contact with, or inhalation of dusts arising from cutting applications may endanger the health of the operator and possible bystanders. Wear a dust mask specifically designed for protection against dust and fumes and ensure that persons within or entering the work area are also protected.

- ◆ The intended use is described in this instruction manual.
- ◆ The use of any accessory or attachment or performance of any operation with this tool other than those recommended in this instruction manual may present a risk of personal injury and/or damage to property.

Safety of others

- ◆ This tool is not intended for use by persons (including children) with reduced physical, sensory or mental capabilities, or lack of experience and knowledge, unless they

have been given supervision or instruction concerning use of the appliance by a person responsible for their safety.

- ◆ Children should be supervised to ensure that they do not play with the appliance.

Residual risks

Additional residual risks may arise when using the tool which may not be included in the enclosed safety warnings. These risks can arise from misuse, prolonged use etc.

Even with the application of the relevant safety regulations and the implementation of safety devices, certain residual risks can not be avoided. These include:

- ◆ Injuries caused by touching any rotating/moving parts.
- ◆ Injuries caused when changing any parts, blades or accessories.
- ◆ Injuries caused by prolonged use of a tool. When using any tool for prolonged periods ensure you take regular breaks.
- ◆ Impairment of hearing.
- ◆ Health hazards caused by breathing dust developed when using your tool (example:- working with wood, especially oak, beech and MDF.)

Vibration

The declared vibration emission values stated in the technical data and the declaration of conformity have been measured in accordance with a standard test method provided by EN 62841 and may be used for comparing one tool with another.

The declared vibration emission value may also be used in a preliminary assessment of exposure.

Warning! The vibration emission value during actual use of the power tool can differ from the declared value depending on the ways in which the tool is used. The vibration level may increase above the level stated.

When assessing vibration exposure to determine safety measures required by 2002/44/EC to protect persons regularly using power tools in employment, an estimation of vibration exposure should consider, the actual conditions of use and the way the tool is used, including taking account of all parts of the operating cycle such as the times when the tool is switched off and when it is running idle in addition to the trigger time.

Labels on tool

The following pictograms along with the date code are shown on the tool:



Warning! To reduce the risk of injury, the user must read the instruction manual.



Visible radiation. Do not stare into light.

Additional safety instructions for batteries and chargers

Batteries

- ◆ Never attempt to open for any reason.
- ◆ Do not expose the battery to water.
- ◆ Do not store in locations where the temperature may exceed 40 °C.
- ◆ Charge only at ambient temperatures between 10 °C and 40 °C.
- ◆ Charge only using the charger provided with the tool.
- ◆ When disposing of batteries, follow the instructions given in the section "Protecting the environment".



Do not attempt to charge damaged batteries.

Chargers

- ◆ Use your STANLEY FATMAX charger only to charge the battery in the tool with which it was supplied. Other batteries could burst, causing personal injury and damage.
- ◆ Never attempt to charge non-rechargeable batteries.
- ◆ Have defective cords replaced immediately.
- ◆ Do not expose the charger to water.
- ◆ Do not open the charger.
- ◆ Do not probe the charger.



The charger is intended for indoor use only.



Read the instruction manual before use.

Electrical safety



Your charger is double insulated; therefore no earth wire is required. Always check that the mains voltage corresponds to the voltage on the rating plate. Never attempt to replace the charger unit with a regular mains plug.

- ◆ If the supply cord is damaged, it must be replaced by the manufacturer or an authorised STANLEY FATMAX Service Centre in order to avoid a hazard.

Features

This tool includes some or all of the following features.

1. Battery
2. Battery release button
3. Main handle
4. Variable-speed trigger
5. Lock-off button
6. Tool free blade release
7. Blade

8. Keyless bevel lever
9. Shoe
10. Shoe cover
11. Orbital action selector

Assembly



Warning! Before assembly, remove the battery from the tool and make sure that the saw blade has stopped. Used saw blades may be hot.

Charging the battery (Fig. A)

The battery needs to be charged before first use and whenever it fails to produce sufficient power on jobs that were easily done before.

The battery may become warm while charging; this is normal and does not indicate a problem.

Warning! Do not charge the battery at ambient temperatures below 10 °C or above 40 °C. Recommended charging temperature: approx. 24 °C.

Note: The charger will not charge a battery if the cell temperature is below approximately 10 °C or above 40 °C. The battery should be left in the charger and the charger will begin to charge automatically when the cell temperature warms up or cools down.

Note: To ensure maximum performance and life of lithium-ion battery packs, charge the battery pack fully before first use.

- ◆ Plug the charger (12) into an appropriate outlet before inserting battery pack (1).
- ◆ The green charging light (12a) will blink continuously indicating that the charging process has started.
- ◆ The completion of charge will be indicated by the green charging light (12a) remaining ON continuously. The battery pack (1) is fully charged and may be removed and used at this time or left in the charger (12).
- ◆ Charge discharged batteries within 1 week. Battery life will be greatly diminished if stored in a discharged state.

Charger LED Modes

	Charging: Green LED Intermittent	
	Fully Charged: Green LED Solid	
	Hot/Cold Pack Delay: Green LED Intermittent Red LED Solid	

Note: The compatible charger(s) will not charge a faulty battery pack. The charger will indicate a faulty battery pack by refusing to light.

Note: This could also mean a problem with a charger. If the charger indicates a problem, take the charger and battery pack to be tested at an authorized service centre.

Leaving the battery in the charger

The charger and battery pack can be left connected with the LED glowing indefinitely. The charger will keep the battery pack fresh and fully charged.

Hot/Cold Pack Delay

When the charger detects a battery that is too hot or too cold, it automatically starts a Hot/Cold Pack Delay, the green LED (12a) will flash intermittently, while the red LED (12b) will remain on continuously, suspending charging until the battery has reached an appropriate temperature. The charger then automatically switches to the pack charging mode. This feature ensures maximum battery life.

Battery state of charge indicator (Fig. B)

The battery includes a state of charge indicator to quickly determine the extent of battery life as shown in figure B. By pressing the state of charge button (1a) you can easily view the charge remaining in the battery as illustrated in figure B.

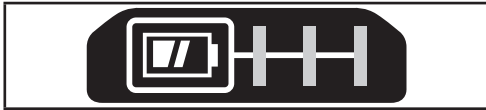

Installing and Removing the Battery Pack from the tool

Warning! Make certain the lock-off button is engaged to prevent switch actuation before removing or installing battery.

To install battery pack (Fig. C)

- ◆ Insert battery pack (1) firmly into tool until an audible click is heard as shown in figure C. Ensure battery pack is fully seated and fully latched into position.

To remove battery pack (Fig. C)

- ◆ Depress the battery release button (2) as shown in figure C and pull battery pack out of tool.

Fitting and removing the saw blade (Fig. D)

- ◆ Hold the saw blade (7) with the teeth facing forward.
- ◆ Push the saw blade release lever (6) downwards.
- ◆ Insert the shank of the blade fully into the blade clamp as far as it will go.
- ◆ Release the lever.
- ◆ To remove saw blade (7), push the saw blade release lever (6) downwards and pull the blade out.



Warning! The blade may become hot after use. Always wear gloves when removing a blade.

Switching on and off (Fig. F)

- ◆ To switch on, slide the lock off button (5) to the left then pull and hold the variable speed trigger switch (4).
- ◆ To switch off, release the trigger switch (4).



Warning! Do not switch the tool on or off while under load.



Warning! Always slide the lock off button (5) to the right, the locked position when the tool is not in use.

Variable speed control

The variable speed on/off switch offers a choice of speeds for greatly improved cutting rates in various materials.

- The speed is determined by the amount the trigger switch (4) is pulled.

Removeable anti-scratch shoe cover (Fig. E)

The anti-scratch shoe cover (10) should be used when cutting surfaces that scratch easily, such as laminate, veneer or paint. To attach anti-scratch shoe cover (10), place the front of the aluminum shoe (9) into the front of the anti-scratch shoe cover and lower the jig saw. The anti-scratch shoe cover will click securely onto the rear of aluminum shoe.

To remove anti-scratch shoe cover, grasp the anti-scratch shoe cover from the bottom; holding onto the two rear tabs remove the anti-scratch shoe cover.

Correct hand position (Fig. F)

Warning! To reduce the risk of serious personal injury, ALWAYS use proper hand position as shown.

Warning! To reduce the risk of serious personal injury, ALWAYS hold securely in anticipation of a sudden reaction. Proper hand position requires one hand on the main handle (3).

Beveling the shoe (Fig. G)

- ◆ To unlock the shoe, pull the keyless bevel lever (8) to the side.
- ◆ To lock the shoe, push the keyless bevel lever (8) back under the body of the jigsaw.

To bevel the shoe

- ◆ Unlock the shoe.
- ◆ Slide the shoe (9) forward to release it from the 0° positive stop position.
- ◆ The shoe can be beveled to the left or to the right and has detents at 0°, 22.5° and 45°. The shoe can be manually stopped at any degree between 0° and 45°.
- ◆ Once the desired bevel angle is achieved, lock the shoe into place.

To set shoe back to 0°

- ◆ Unlock the shoe.
- ◆ Rotate the shoe back to 0°.
- ◆ Slide the shoe back into the 0° positive stop position.
- ◆ Lock the shoe.

Cutting (Fig. H)

Warning! Always use eye protection. All users and bystanders must wear eye protection.

Warning! Exercise extra caution when cutting towards operator. Always hold saw firmly while cutting.

The blade should extend past the pivoting shoe and the thickness of the workpiece throughout the cut. Select the blade best suitable for the material to be cut and use the shortest blade suitable for the thickness of the material.

Cutting action

Orbital or straight (Fig. I)

Warning! Check that the tool is not locked on before connecting it to a power supply. If the trigger switch is locked on when the tool is connected to the power supply, it will start immediately. Damage to your tool or personal injury may result. This jig saw is equipped with four cutting actions, three orbital and one straight. 1 Orbital action has a more aggressive blade motion and is designed for cutting in soft materials like wood or plastic. 2 Orbital action is suitable for thick wood pieces. 3 Orbital action provides a faster cut, but with a less smooth cut across the material. In orbital action, the blade moves forward during the cutting stroke in addition to the up and down motion.

Note: Metal or hardwoods should never be cut in orbital action.

To adjust the cutting action

- ◆ Move the orbital action selector (11) between the four cutting positions: 0, 1, 2 and 3. Position 0 is straight cutting. Positions 1, 2 and 3 are orbital cutting. The aggressiveness of the cut increases as the orbital action selector is adjusted from one to three, with three being the most aggressive cut.

Hints for optimum use

Tips for sawing laminates

- ◆ As the saw blade cuts on the upward stroke, splintering may occur on the surface closest to the shoe plate.
- ◆ Use a fine-tooth saw blade.
- ◆ Saw from the back surface of the workpiece.
- ◆ To minimize splintering, clamp a piece of scrap wood or hardboard to both sides of the workpiece and saw through this sandwich.

Tips for sawing metal

- ◆ Be aware that sawing metal takes much more time than sawing wood.
- ◆ Use a saw blade suitable for sawing metal.
- ◆ When cutting thin metal, clamp a piece of scrap wood to the back surface of the workpiece and cut through this sandwich.
- ◆ Spread a film of oil along the intended line of cut for easier operation and longer blade life. For cutting aluminum, kerosene is preferred.

Pocket cutting (Fig. J, K)

A pocket cut is an easy method of making an inside cut.

The saw can be inserted directly into a panel or board without first drilling a lead or pilot hole. In pocket cutting, measure the surface to be cut and mark clearly with a pencil.

Next tip the saw forward until the front end of the shoe sits firmly on the work surface and the blade clears the work through its full stroke. Switch the tool on and allow it to attain maximum speed. Grip the saw firmly and lower the back edge of tool slowly until the blade reaches its complete depth. Hold the shoe flat against the wood and begin cutting. Do not remove blade from cut while it is still moving. Blade must come to a complete stop.

Accessories

The performance of your tool depends on the accessory used. STANLEY FATMAX accessories are engineered to high quality standards and designed to enhance the performance of your tool. By using these accessories you will get the very best from your tool. This tool is suitable both for U-shank and T-shank saw blades.

Maintenance

Your STANLEY FATMAX tool has been designed to operate over a long period of time with a minimum of maintenance. Continuous satisfactory operation depends upon proper tool care and regular cleaning.

Your charger does not require any maintenance apart from regular cleaning.



Warning! Before performing any maintenance on the tool, remove the battery from the tool. Unplug the charger before cleaning it.

- Regularly clean the ventilation slots in your tool and charger using a soft brush or dry cloth.
- Regularly clean the motor housing using a damp cloth. Do not use any abrasive or solvent-based cleaner.

Protecting the environment



Separate collection. Products and batteries marked with this symbol must not be disposed of with normal household waste.

Products and batteries contain materials that can be recovered or recycled, reducing demand for raw materials. Please recycle electrical products and batteries according to local provisions. Further information is available at www.2helpU.com

Technical data

SFMC650 (H1)		
Voltage	V _{ac}	18
No-load speed	min ⁻¹	0 - 3200
Stroke length	mm	25.4
Max depth of cut		
Wood	mm	85
Steel	mm	10
Aluminium	mm	25
Weight	kg	1.93

Charger		SFMCB11	SFMCB12	SFMCB14
Input Voltage	V_{AC}	230	230	230
Output Voltage	V_{DC}	18	18	18
Current	A	1.25	2	4

Battery		SFMCB201	SFMCB202	SFMCB204	SFMCB206
Voltage	V_{DC}	18	18	18	18
Capacity	Ah	1.5	2.0	4.0	6.0
Type		Li-Ion	Li-Ion	Li-Ion	Li-Ion

Level of sound pressure according to EN62841: L_{pA} (sound pressure) 84 dB(A), Uncertainty (K) 5 dB(A)	
L_{WA} (sound power) 95 dB(A), Uncertainty (K) 5 dB(A)	
Vibration total values (triax vector sum) according to EN62841:	
Cutting boards ($a_{h, \text{avg}}$) 4.5 m/s ² , uncertainty (K) 1.5 m/s ²	
Cutting sheet metal ($a_{h, \text{avg}}$) 6.4 m/s ² , uncertainty (K) 1.5 m/s ²	

Supply of Machinery (Safety) Regulations 2008



SFMC650 Jigsaw

Stanley Fatmax declares that these products described under "technical data" are in compliance with:

The Supply of Machinery (Safety) Regulations, 2008, S.I. 2008/1597 (as amended),
EN62841-1:2015 , EN62841-2-11:2016.

These products conform to the following UK Regulations:
Electromagnetic Compatibility Regulations, 2016,
S.I.2016/1091 (as amended).

The Restriction of the Use of Certain Hazardous Substances in Electrical and Electronic Equipment Regulations 2012, S.I. 2012/3032 (as amended).

For more information, please contact Stanley Fatmax at the following address or refer to the back of the manual.

The undersigned is responsible for compilation of the technical file and makes this declaration on behalf of Stanley Fatmax

Karl Evans
Vice President - Professional Power Tools
Stanley Fatmax UK, 270 Bath Road, Slough
Berkshire, SL1 4DX
United Kingdom
10/09/2021

EC declaration of conformity MACHINERY DIRECTIVE



SFMC650 Jigsaw

Stanley Fatmax declares that these products described under "technical data" are in compliance with:

2006/42/EC, EN62841-1:2015 , EN62841-2-11:2016.
These products also comply with Directive 2014/30/EU and 2011/65/EU. For more information, please contact Stanley Fatmax at the following address or refer to the back of the manual.

The undersigned is responsible for compilation of the technical file and makes this declaration on behalf of Stanley Fatmax.

Patrick Diepenbach
General Manager, Benelux
Stanley Fatmax,
Egide Walschaertsstraat 14-18
2800 Mechelen, Belgium
10/09/2021

Guarantee

STANLEY FATMAX is confident of the quality of its products and offers consumers a 12 month guarantee from the date of purchase. This guarantee is in addition to and in no way prejudices your statutory rights. The guarantee is valid within the territories of the Member States of the European Union and the European Free Trade Area.

To claim on the guarantee, the claim must be in accordance with STANLEY FATMAX Terms and Conditions and you will need to submit proof of purchase to the seller or an authorised repair agent.

Terms and conditions of the STANLEY FATMAX 1 year guarantee and the location of your nearest authorised repair agent can be obtained on the Internet at www.2helpU.com, or by contacting your local STANLEY FATMAX office at the address indicated in this manual.

Please visit our website www.stanleytools.eu/3 to register your new STANLEY FATMAX product and receive updates on new products and special offers.

United Kingdom

Stanley Fat Max
270 Bath Road
Slough, Berkshire SL1 4DX

Tel. 01753 511234
Fax 01753 572112
www.stanleytools.co.uk