

**STANLEY®**

**FATMAX®**

**WWW.STANLEY.EU**

**SFMCM300**



Fig. A

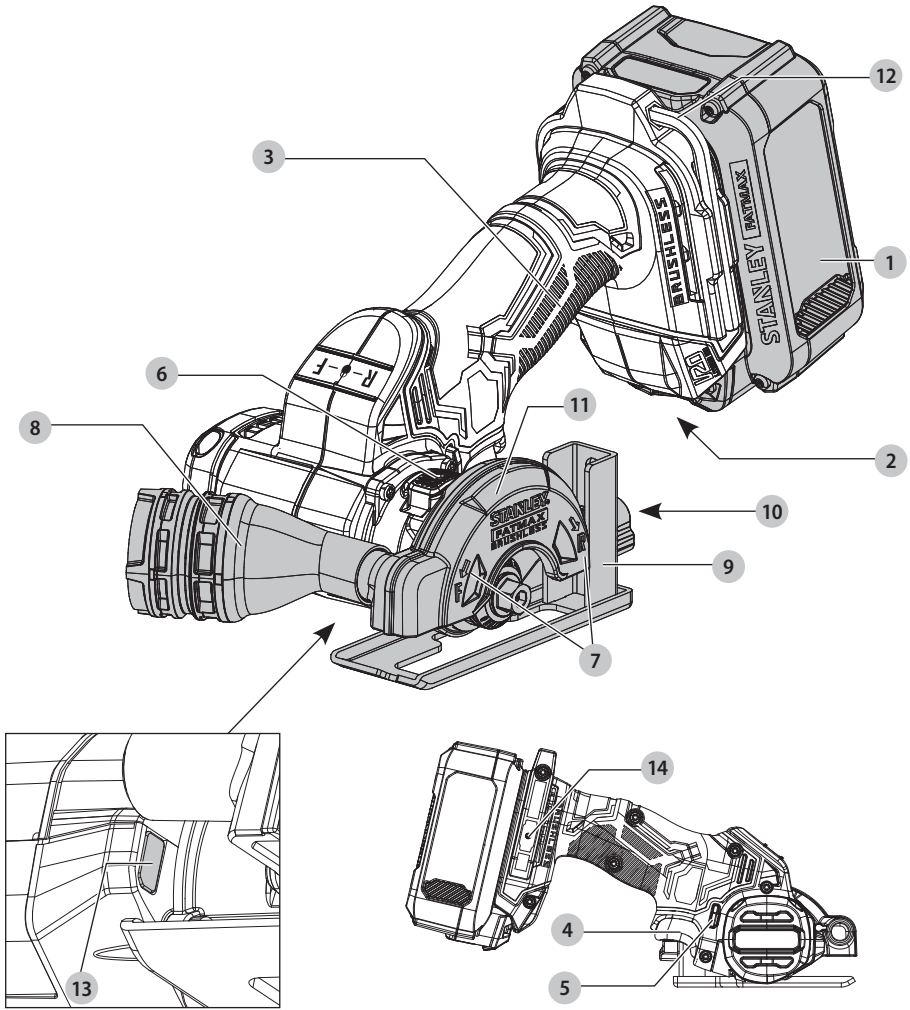

Fig. B

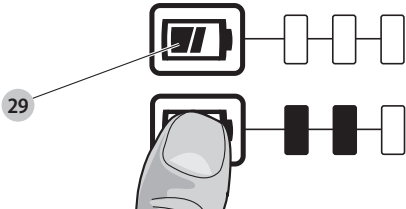

Fig. C

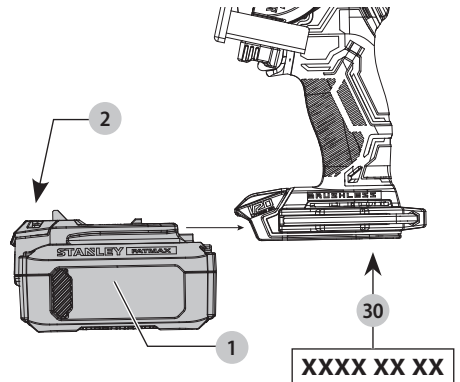

Fig. D1

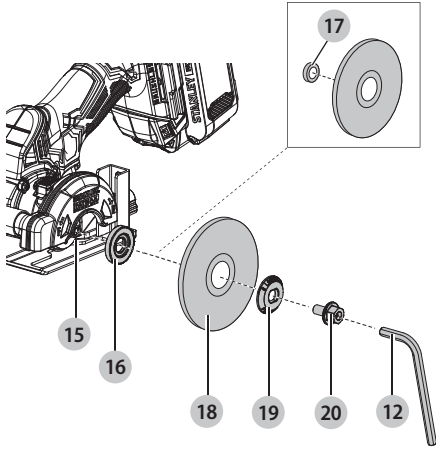

Fig. D2

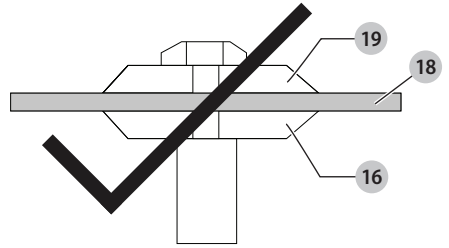

Fig. E

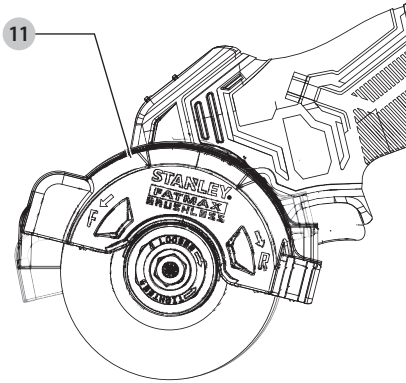

Fig. F

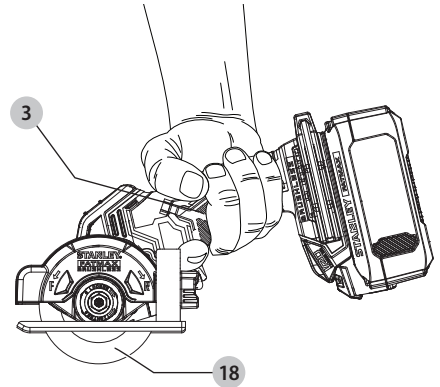

Fig. G

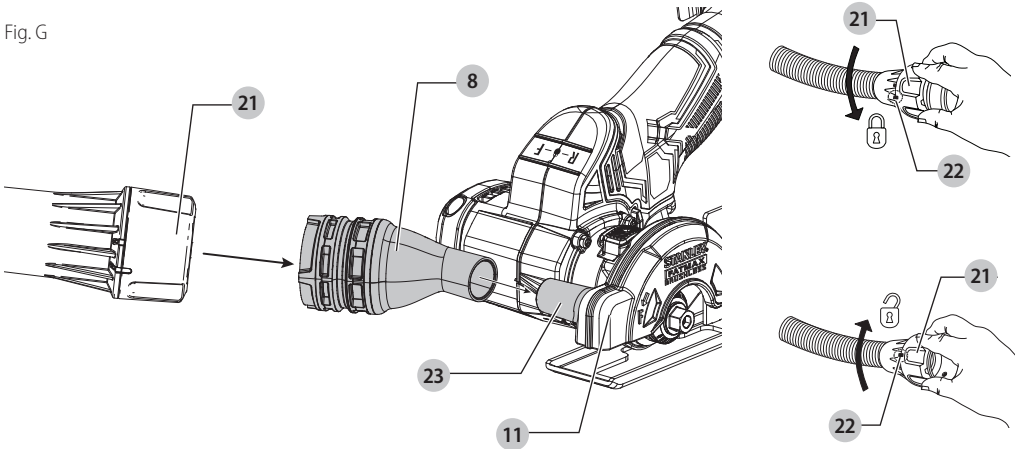

Fig. H1

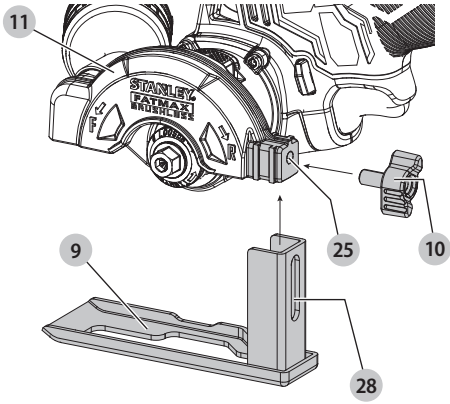

Fig. H2

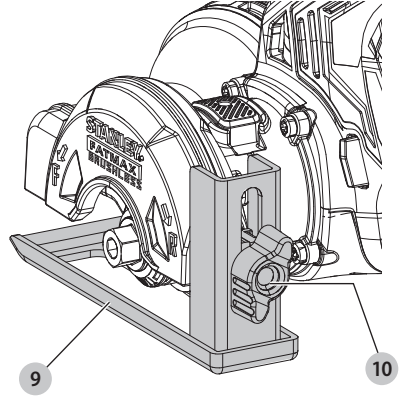

Fig. I1

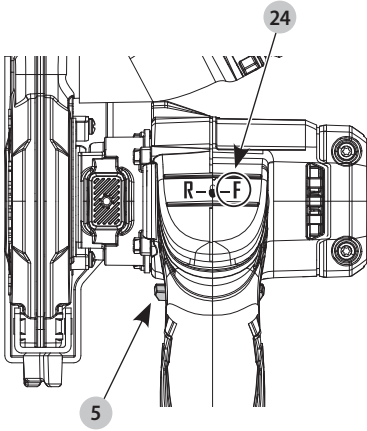

Fig. I2

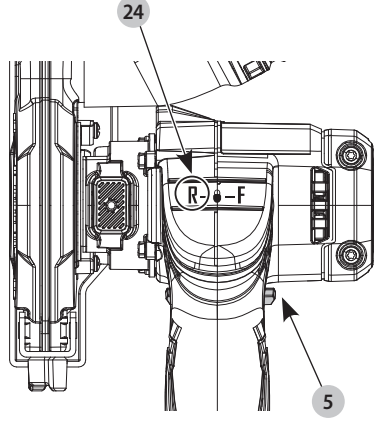

Fig. J

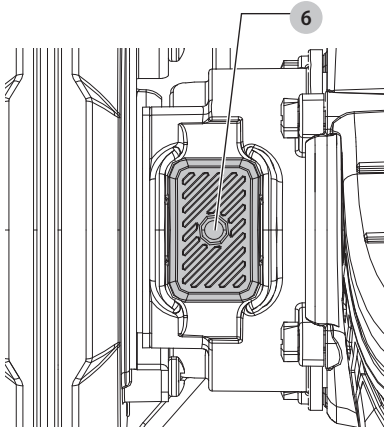

Fig. K

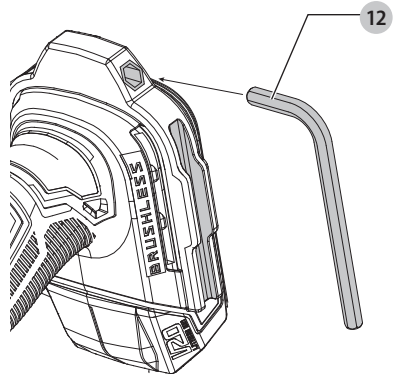
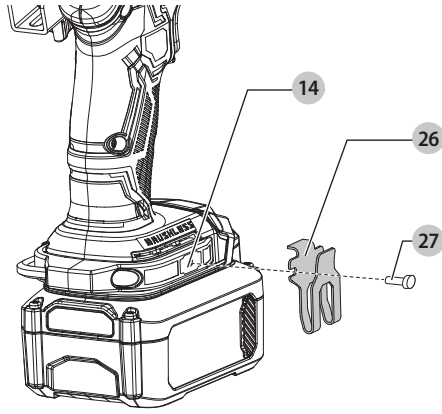

Fig. L



# 18V CORDLESS CUTOFF TOOL

## SFMCM300

### Congratulations!

You have chosen a STANLEY FATMAX tool. Years of experience, thorough product development and innovation make STANLEY FATMAX one of the most reliable partners for professional power tool users.

### Technical Data

SFMCM300		
Voltage	V <sub>DC</sub>	18
Type		1
Battery type		Li-Ion
No-load/rated speed	min <sup>-1</sup>	20000
Wheel diameter	mm	76
Wheel thickness (max)	mm	2.2
Spindle diameter	mm	10
Spindle length	mm	43
Weight (without battery pack)	kg	0.94
Noise values and/or vibration values (tri-ax vector sum) according to EN60745-2-22:		
L <sub>PA</sub> (emission sound pressure level)	dB(A)	98
L <sub>WA</sub> (sound power level)	dB(A)	109
K (uncertainty for the given sound level)	dB(A)	3
Vibration emission value a <sub>h</sub> =		
	m/s <sup>2</sup>	1.6
Uncertainty K =		
	m/s <sup>2</sup>	1.5

The vibration and/or noise emission level given in this information sheet has been measured in accordance with a standardised test given in EN60745 and may be used to compare one tool with another. It may be used for a preliminary assessment of exposure.



**WARNING:** *The declared vibration and/or noise emission level represents the main applications of the tool. However, if the tool is used for different applications, with different accessories or is poorly maintained, the vibration and/or noise emission may differ. This may significantly increase the exposure level over the total working period.*

*An estimation of the level of exposure to vibration and/or noise should also take into account the times when the tool is switched off or when it is running but not actually doing the job. This may significantly reduce the exposure level over the total working period.*

*Identify additional safety measures to protect the operator from the effects of vibration and/or noise such as: maintain the tool and the accessories, keep the hands warm (relevant for vibration), organisation of work patterns.*

### EC-Declaration of Conformity

#### Machinery Directive



#### 18V Cordless CutOff Tool SFMCM300

STANLEY FATMAX declares that these products described under **Technical Data** are in compliance with: 2006/42/EC, EN60745-1:2009+A11:2010, EN60745-2-22:2011+A11:2013.

These products also comply with Directive 2014/30/EU and 2011/65/EU. For more information, please contact STANLEY FATMAX at the following address or refer to the back of the manual.

The undersigned is responsible for compilation of the technical file and makes this declaration on behalf of STANLEY FATMAX.

*Patrick Diepenbach*

Patrick Diepenbach  
General Manager Benelux, GTS-Europe  
STANLEY FATMAX Europe, Egide Walschaertsstraat14-18,  
2800 Mechelen, Belgium  
09.30.2023

### DECLARATION OF CONFORMITY THE SUPPLY OF MACHINERY (SAFETY) REGULATIONS 2008



#### 18V Cordless CutOff Tool SFMCM300

STANLEY FATMAX declares that these products described under **Technical Data** are in compliance with:

The Supply of Machinery (Safety) Regulations, 2008, S.I. 2008/1597 (as amended), EN60745-1:2009+A11:2010, EN60745-2-22:2011+A11:2013.

These products conform to the following UK Regulations: Electromagnetic Compatibility Regulations, 2016, S.I.2016/1091 (as amended).

The Restriction of the Use of Certain Hazardous Substances in Electrical and Electronic Equipment Regulations 2012, S.I. 2012/3032 (as amended).

For more information, please contact STANLEY FATMAX at the following address or refer to the back of the manual.

The undersigned is responsible for compilation of the technical file and makes this declaration on behalf of STANLEY FATMAX.



Karl Evans  
Vice President - Professional Power Tools  
STANLEY FATMAX UK, 270 Bath Road, Slough  
Berkshire, SL1 4DX  
United Kingdom  
09.30.2023



**WARNING:** To reduce the risk of injury, read the instruction manual.

## Definitions: Safety Guidelines

The definitions below describe the level of severity for each signal word. Please read the manual and pay attention to these symbols.



**DANGER:** Indicates an imminently hazardous situation which, if not avoided, **will** result in **death or serious injury**.



**WARNING:** Indicates a potentially hazardous situation which, if not avoided, **could** result in **death or serious injury**.



**CAUTION:** Indicates a potentially hazardous situation which, if not avoided, **may** result in **minor or moderate injury**.

**NOTICE:** Indicates a practice **not related to personal injury** which, if not avoided, **may** result in **property damage**.



Denotes risk of electric shock.



Denotes risk of fire.

## GENERAL POWER TOOL SAFETY WARNINGS



**WARNING:** Read all safety warnings, instructions, illustrations and specifications provided with this power tool. Failure to follow all instructions listed below may result in electric shock, fire and/or serious injury.

## SAVE ALL WARNINGS AND INSTRUCTIONS FOR FUTURE REFERENCE

The term "power tool" in the warnings refers to your mains-operated (corded) power tool or battery-operated (cordless) power tool.

### 1) Work Area Safety

- Keep work area clean and well lit.** Cluttered or dark areas invite accidents.
- Do not operate power tools in explosive atmospheres, such as in the presence of flammable liquids, gases or dust.** Power tools create sparks which may ignite the dust or fumes.
- Keep children and bystanders away while operating a power tool.** Distractions can cause you to lose control.

### 2) Electrical Safety

- Power tool plugs must match the outlet. Never modify the plug in any way. Do not use any adapter plugs with earthed (grounded) power tools.**  
Unmodified plugs and matching outlets will reduce risk of electric shock.
- Avoid body contact with earthed or grounded surfaces, such as pipes, radiators, ranges and refrigerators.** There is an increased risk of electric shock if your body is earthed or grounded.
- Do not expose power tools to rain or wet conditions.**  
Water entering a power tool will increase the risk of electric shock.
- Do not abuse the cord. Never use the cord for carrying, pulling or unplugging the power tool. Keep cord away from heat, oil, sharp edges or moving parts.** Damaged or entangled cords increase the risk of electric shock.
- When operating a power tool outdoors, use an extension cord suitable for outdoor use.** Use of a cord suitable for outdoor use reduces the risk of electric shock.
- If operating a power tool in a damp location is unavoidable, use a residual current device (RCD) protected supply.** Use of an RCD reduces the risk of electric shock.

### 3) Personal Safety

- Stay alert, watch what you are doing and use common sense when operating a power tool. Do not use a power tool while you are tired or under the influence of drugs, alcohol or medication.** A moment of inattention while operating power tools may result in serious personal injury.
- Use personal protective equipment. Always wear eye protection.** Protective equipment such as a dust mask, non-skid safety shoes, hard hat or hearing protection used for appropriate conditions will reduce personal injuries.
- Prevent unintentional starting. Ensure the switch is in the off position before connecting to power source and/or battery pack, picking up or carrying the tool.** Carrying power tools with your finger on the switch or energising power tools that have the switch on invites accidents.
- Remove any adjusting key or wrench before turning the power tool on.** A wrench or a key left attached to a rotating part of the power tool may result in personal injury.
- Do not overreach. Keep proper footing and balance at all times.** This enables better control of the power tool in unexpected situations.
- Dress properly. Do not wear loose clothing or jewellery. Keep your hair and clothing away from moving parts.** Loose clothes, jewellery or long hair can be caught in moving parts.
- If devices are provided for the connection of dust extraction and collection facilities, ensure these are connected and properly used.** Use of dust collection can reduce dust-related hazards.



- h) **Do not let familiarity gained from frequent use of tools allow you to become complacent and ignore tool safety principles.** A careless action can cause severe injury within a fraction of a second.

#### 4) Power Tool Use and Care

- a) **Do not force the power tool. Use the correct power tool for your application.** The correct power tool will do the job better and safer at the rate for which it was designed.
- b) **Do not use the power tool if the switch does not turn it on and off.** Any power tool that cannot be controlled with the switch is dangerous and must be repaired.
- c) **Disconnect the plug from the power source and/ or remove the battery pack, if detachable, from the power tool before making any adjustments, changing accessories, or storing power tools.** Such preventive safety measures reduce the risk of starting the power tool accidentally.
- d) **Store idle power tools out of the reach of children and do not allow persons unfamiliar with the power tool or these instructions to operate the power tool.** Power tools are dangerous in the hands of untrained users.
- e) **Maintain power tools and accessories. Check for misalignment or binding of moving parts, breakage of parts and any other condition that may affect the power tool's operation. If damaged, have the power tool repaired before use.** Many accidents are caused by poorly maintained power tools.
- f) **Keep cutting tools sharp and clean.** Properly maintained cutting tools with sharp cutting edges are less likely to bind and are easier to control.
- g) **Use the power tool, accessories and tool bits, etc. in accordance with these instructions, taking into account the working conditions and the work to be performed.** Use of the power tool for operations different from those intended could result in a hazardous situation.
- h) **Keep handles and grasping surfaces dry, clean and free from oil and grease.** Slippery handles and grasping surfaces do not allow for safe handling and control of the tool in unexpected situations.

#### 5) Battery Tool Use and Care

- a) **Recharge only with the charger specified by the manufacturer.** A charger that is suitable for one type of battery pack may create a risk of fire when used with another battery pack.
- b) **Use power tools only with specifically designated battery packs.** Use of any other battery packs may create a risk of injury and fire.
- c) **When battery pack is not in use, keep it away from other metal objects, like paper clips, coins, keys, nails, screws or other small metal objects, that can make a connection from one terminal to another.** Shorting the battery terminals together may cause burns or a fire.
- d) **Under abusive conditions, liquid may be ejected from the battery; avoid contact. If contact accidentally occurs, flush with water. If liquid**

**contacts eyes, additionally seek medical help.** Liquid ejected from the battery may cause irritation or burns.

- e) **Do not use a battery pack or tool that is damaged or modified.** Damaged or modified batteries may exhibit unpredictable behaviour resulting in fire, explosion or risk of injury.
- f) **Do not expose a battery pack or tool to fire or excessive temperature.** Exposure to fire or temperature above 130 °C may cause explosion.
- g) **Follow all charging instructions and do not charge the battery pack or tool outside the temperature range specified in the instructions.** Charging improperly or at temperatures outside the specified range may damage the battery and increase the risk of fire.

#### 6) Service

- a) **Have your power tool serviced by a qualified repair person using only identical replacement parts.** This will ensure that the safety of the power tool is maintained.
- b) **Never service damaged battery packs.** Service of battery packs should only be performed by the manufacturer or authorised service providers.

#### CUT-OFF MACHINE SAFETY WARNINGS

- a) **The guard provided with the tool must be securely attached to the power tool and positioned for maximum safety, so the least amount of wheel is exposed towards the operator. Position yourself and bystanders away from the plane of the rotating wheel.** The guard helps to protect operator from broken wheel fragments and accidental contact with wheel.
- b) **Use only bonded reinforced or diamond cut-off wheels for your power tool.** Just because an accessory can be attached to your power tool, it does not assure safe operation.
- c) **The rated speed of the accessory must be at least equal to the maximum speed marked on the power tool.** Accessories running faster than their rated speed can break and fly apart.
- d) **Wheels must be used only for recommended applications. For example: do not grind with the side of cut-off wheel.** Abrasive cut-off wheels are intended for peripheral grinding, side forces applied to these wheels may cause them to shatter.
- e) **Always use undamaged wheel flanges that are of correct diameter for your selected wheel.** Proper wheel flanges support the wheel thus reducing the possibility of wheel breakage.
- f) **Do not use worn down reinforced wheels from larger power tools.** Wheels intended for a larger power tool are not suitable for the higher speed of a smaller tool and may burst.
- g) **The outside diameter and the thickness of your accessory must be within the capacity rating of your power tool.** Incorrectly sized accessories cannot be adequately guarded or controlled.

- h) **The arbour size of wheels and flanges must properly fit the spindle of the power tool.** Wheels and flanges with arbour holes that do not match the mounting hardware of the power tool will run out of balance, vibrate excessively and may cause loss of control.
- i) **Do not use damaged wheels. Before each use, inspect the wheels for chips and cracks. If power tool or wheel is dropped, inspect for damage or install an undamaged wheel. After inspecting and installing the wheel, position yourself and bystanders away from the plane of the rotating wheel and run the power tool at maximum no load speed for one minute.** Damaged wheels will normally break apart during this test time.
- j) **Wear personal protective equipment. Depending on application, use face shield, safety goggles or safety glasses. As appropriate, wear dust mask, hearing protectors, gloves and shop apron capable of stopping small abrasive or workpiece fragments.** The eye protection must be capable of stopping flying debris generated by various operations. The dust mask or respirator must be capable of filtering particles generated by your operation. Prolonged exposure to high intensity noise may cause hearing loss.
- k) **Keep bystanders a safe distance away from work area. Anyone entering the work area must wear personal protective equipment.** Fragments of workpiece or of a broken wheel may fly away and cause injury beyond immediate area of operation.
- l) **Hold the power tool by insulated gripping surfaces only, when performing an operation where the cutting accessory may contact hidden wiring.** Cutting accessory contacting a "live" wire may make exposed metal parts of the power tool "live" and could give the operator an electric shock.
- m) **Never lay the power tool down until the accessory has come to a complete stop.** The spinning wheel may grab the surface and pull the power tool out of your control.
- n) **Do not run the power tool while carrying it at your side.** Accidental contact with the spinning accessory could snag your clothing, pulling the accessory into your body.
- o) **Regularly clean the power tool's air vents.** The motor's fan will draw the dust inside the housing and excessive accumulation of powdered metal may cause electrical hazards.
- p) **Do not operate the power tool near flammable materials.** Sparks could ignite these materials.
- q) **Do not use accessories that require liquid coolants.** Using water or other liquid coolants may result in electrocution or shock.

## FURTHER SAFETY INSTRUCTIONS FOR ABRASIVE CUTTING-OFF OPERATIONS

### Kickback and Related Warnings

Kickback is a sudden reaction to a pinched or snagged rotating wheel, backing pad, brush or any other accessory. Pinching or snagging causes rapid stalling of the rotating accessory which in turn causes the uncontrolled power tool to be forced in the direction opposite of the accessory's rotation at the point of the binding.

For example, if an abrasive wheel is snagged or pinched by the workpiece, the edge of the wheel that is entering into the pinch point can dig into the surface of the material causing the wheel to climb out or kick out. The wheel may either jump toward or away from the operator, depending on direction of the wheel's movement at the point of pinching. Abrasive wheels may also break under these conditions.

Kickback is the result of power tool misuse and/or incorrect operating procedures or conditions and can be avoided by taking proper precautions as given below:

- Maintain a firm grip on the power tool and position your body and arm to allow you to resist kickback forces. Always use auxiliary handle, if provided, for maximum control over kickback or torque reaction during start-up.** The operator can control torque reaction or kickback forces, if proper precautions are taken.
- Never place your hand near the rotating accessory.** Accessory may kickback over your hand.
- Do not position your body in line with the rotating wheel.** Kickback will propel the tool in direction opposite to the wheel's movement at the point of snagging.
- Use special care when working corners, sharp edges etc. Avoid bouncing and snagging the accessory.** Corners, sharp edges or bouncing have a tendency to snag the rotating accessory and cause loss of control or kickback.
- Do not attach a saw chain, woodcarving blade, segmented diamond wheel with a peripheral gap greater than 10 mm or toothed saw blade.** Such blades create frequent kickback and loss of control.
- Do not "jam" the wheel or apply excessive pressure. Do not attempt to make an excessive depth of cut.** Overstressing the wheel increases the loading and susceptibility to twisting or binding of the wheel in the cut and the possibility of kickback or wheel breakage.
- When wheel is binding or when interrupting a cut for any reason, switch off the power tool and hold the power tool motionless until the wheel comes to a complete stop. Never attempt to remove the wheel from the cut while the wheel is in motion otherwise kickback may occur.** Investigate and take corrective action to eliminate the cause of wheel binding.
- Do not restart the cutting operation in the workpiece. Let the wheel reach full speed and carefully re-enter the cut.** The wheel may bind, walk up or kickback if the power tool is restarted in the workpiece.

- i) **Support panels or any oversized workpiece to minimize the risk of wheel pinching and kickback.** Large workpieces tend to sag under their own weight. Supports must be placed under the workpiece near the line of cut and near the edge of the workpiece on both sides of the wheel.
- j) **Use extra caution when making a “pocket cut” into existing walls or other blind areas. The protruding wheel may cut gas or water pipes, electrical wiring or objects that can cause kickback.**

## Additional Safety Warnings for Abrasive Cutting-Off Operations:

- a) **This power tool is intended to function as a cut-off tool. Read all safety warnings, instructions, illustrations and specifications provided with this power tool.** Failure to follow all instructions listed below may result in electric shock, fire and/or serious injury.
- b) **Operations such as grinding, sanding, wire brushing, or polishing are not recommended to be performed with this power tool.** Operations for which the power tool was not designed may create a hazard and cause personal injury. Do not surface grind with side of wheel.
- c) **Do not use accessories which are not specifically designed and recommended by the tool manufacturer.** Just because the accessory can be attached to your power tool, it does not assure safe operation.
- d) **The outside diameter and the thickness of your accessory must be within the capacity rating of your power tool.** Incorrectly sized accessories cannot be adequately guarded or controlled.
- e) **The arbour size of wheels, flanges, backing pads or any other accessory must properly fit the spindle of the power tool.** Accessories with arbour holes that do not match the mounting hardware of the power tool will run out of balance, vibrate excessively and may cause loss of control.
- f) **When using segmented diamond wheels, use only diamond wheels with a peripheral gap not greater than 10 mm and negative rake angle.**
- g) **Set the depth of cut for no more than necessary. The less wheel exposed, the less chance of binding and kickback.** Before cutting, be sure adjust shoe assembly is tight.
- h) **Do not force the tool.** Forcing a cut off tool reduces control and cutting efficiency.
- i) **If guard is not tight in position, do not use.**
- j) **Do not use toothed blades.**
- k) **Do not use this tool as a table saw.**
- l) **Firmly secure the workpiece.**
- m) **Wear protective clothing and wash exposed areas with soap and water. Allowing dust to get into your mouth, eyes, or lay on the skin may promote**

**absorption of harmful chemicals.** Direct particles away from face and body.

- n) **Use the appropriate dust extractor vacuum to remove the vast majority of static and airborne dust.** Failure to remove static and airborne dust could contaminate the working environment or pose an increased health risk to the operator and those in close proximity.
- o) **Use clamps or other practical ways to secure and support the workpiece to a stable platform.** Holding the work by hand or against your body is unstable and may lead to loss of control and injury.
- p) **Air vents often cover moving parts and should be avoided.** Loose clothes, jewelry or long hair can be caught in moving parts.



**CAUTION:** When not in use, place tool on its side on a stable surface where it will not cause a tripping or falling hazard. Some tools with large battery packs will stand upright on the battery pack but may be easily knocked over.

## Residual Risks

In spite of the application of the relevant safety regulations and the implementation of safety devices, certain residual risks cannot be avoided. These are:

- Impairment of hearing.
- Risk of personal injury due to flying particles.
- Risk of burns due to accessories becoming hot during operation.
- Risk of personal injury due to prolonged use.

## SAVE THESE INSTRUCTIONS

## Chargers

STANLEY FATMAX chargers require no adjustment and are designed to be as easy as possible to operate.

## Electrical Safety

The electric motor has been designed for one voltage only. Always check that the battery pack voltage corresponds to the voltage on the rating plate. Also make sure that the voltage of your charger corresponds to that of your mains.



Your STANLEY FATMAX charger is double insulated in accordance with EN60335; therefore, no earth wire is required.

If the supply cord is damaged, it must be replaced only by STANLEY FATMAX or an authorised service organisation.

## Mains Plug Replacement (U.K. & Ireland Only)

If a new mains plug needs to be fitted:

- Safely dispose of the old plug.
- Connect the brown lead to the live terminal in the plug.
- Connect the blue lead to the neutral terminal.



**WARNING:** No connection is to be made to the earth terminal.

Follow the fitting instructions supplied with good quality plugs. Recommended fuse: 3 A.

## Using an Extension Cable

An extension cord should not be used unless absolutely necessary. Use an approved extension cable suitable for the power input of your charger (refer to **Technical Data**). The minimum conductor size is 1 mm<sup>2</sup>; the maximum length is 30 m. When using a cable reel, always unwind the cable completely.

## Important Safety Instructions for All Battery Chargers

**SAVE THESE INSTRUCTIONS:** This manual contains important safety and operating instructions for compatible battery chargers (refer to **Technical Data**). Before using charger, read all instructions and cautionary markings on charger, battery pack, and product using battery pack.



**WARNING:** Shock hazard. Do not allow any liquid to get inside charger. Electric shock may result.



**WARNING:** We recommend the use of a residual current device with a residual current rating of 30 mA or less.



**CAUTION:** Burn hazard. To reduce the risk of injury, charge only STANLEY FATMAX rechargeable batteries. Other types of batteries may burst, causing personal injury and damage.



**CAUTION:** Children should be supervised to ensure that they do not play with the appliance.

**NOTICE:** Under certain conditions, with the charger plugged into the power supply, the exposed charging contacts inside the charger can be shorted by foreign material. Foreign materials of a conductive nature such as, but not limited to, steel wool, aluminum foil or any buildup of metallic particles should be kept away from the power supply when there is no battery pack in the cavity. Unplug charger before attempting to clean.

- **DO NOT attempt to charge the battery pack with any chargers other than the ones in this manual.** The charger and battery pack are specifically designed to work together.
- **These chargers are not intended for any uses other than charging STANLEY FATMAX rechargeable batteries.** Any other uses may result in risk of fire, electric shock or electrocution.
- **Do not expose charger to rain or snow.**
- **Pull by plug rather than cord when disconnecting charger.** This will reduce risk of damage to electric plug and cord.
- **Make sure that cord is located so that it will not be stepped on, tripped over, or otherwise subjected to damage or stress.**
- **Do not use an extension cord unless it is absolutely necessary.** Use of improper extension cord could result in risk of fire, electric shock, or electrocution.
- **Do not place any object on top of charger or place the charger on a soft surface that might block the ventilation slots and result in excessive internal heat.**

Place the charger in a position away from any heat source. The charger is ventilated through slots in the top and the bottom of the housing.

- **Do not operate charger with damaged cord or plug—** have them replaced immediately.
- **Do not operate charger if it has received a sharp blow, been dropped, or otherwise damaged in any way.** Take it to an authorised service centre.
- **Do not disassemble charger; take it to an authorised service centre when service or repair is required.** Incorrect reassembly may result in a risk of electric shock, electrocution or fire.
- *In case of damaged power supply cord, the supply cord must be replaced immediately by the manufacturer, its service agent or similar qualified person to prevent any hazard.*
- **Disconnect the charger from the outlet before attempting any cleaning. This will reduce the risk of electric shock.** Removing the battery pack will not reduce this risk.
- **NEVER** attempt to connect two chargers together.
- **The charger is designed to operate on standard 230V household electrical power. Do not attempt to use it on any other voltage.** This does not apply to the vehicular charger.

## Charging a Battery (Fig. A)

1. Plug the charger into an appropriate outlet before inserting battery pack.
2. Insert the battery pack ➊ into the charger, making sure the battery pack is fully seated in the charger. The red (charging) light will blink repeatedly, indicating that the charging process has started.
3. The completion of charge will be indicated by the red light remaining ON continuously. The battery pack is fully charged and may be used at this time or left in the charger. To remove the battery pack from the charger, push the battery release button ➋ on the battery pack.

**NOTE:** To ensure maximum performance and life of lithium-ion battery packs, charge the battery pack fully before first use.

## Charger Operation

Refer to the indicators below for the charge status of the battery pack.

Charge Indicators	
Charging	
Fully Charged	
Hot/Cold Pack Delay*	

\*The red light will continue to blink, but a yellow indicator light will be illuminated during this operation. Once the battery pack has reached an appropriate temperature, the yellow light will turn off and the charger will resume the charging procedure.

The compatible charger(s) will not charge a faulty battery pack. The charger will indicate faulty battery by refusing to light.

**NOTE:** This could also mean a problem with a charger.

If the charger indicates a problem, take the charger and battery pack to be tested at an authorised service centre.

### Hot/Cold Pack Delay

When the charger detects a battery pack that is too hot or too cold, it automatically starts a Hot/Cold Pack Delay, suspending charging until the battery pack has reached an appropriate temperature. The charger then automatically switches to the pack charging mode. This feature ensures maximum battery pack life.

A cold battery pack will charge at a slower rate than a warm battery pack. The battery pack will charge at that slower rate throughout the entire charging cycle and will not return to maximum charge rate even if the battery pack warms.

### Electronic Protection System

Li-Ion tools are designed with an Electronic Protection System that will protect the battery pack against overloading, overheating or deep discharge.

The tool will automatically turn off if the Electronic Protection System engages. If this occurs, place the lithium-ion battery pack in the charger until it is fully charged.

### Charger Cleaning Instructions



**WARNING: Shock hazard. Disconnect the charger from the AC outlet before cleaning.** Dirt and grease may be removed from the exterior of the charger using a cloth or soft non-metallic brush. Do not use water or any cleaning solutions. Never let any liquid get inside the tool; never immerse any part of the tool into a liquid.

## Battery Packs

### Important Safety Instructions for All Battery Packs

When ordering replacement battery packs, be sure to include catalogue number and voltage.

The battery pack is not fully charged out of the carton. Before using the battery pack and charger, read the safety instructions below. Then follow charging procedures outlined.

#### READ ALL INSTRUCTIONS

- **Do not charge or use battery in explosive atmospheres, such as in the presence of flammable liquids, gases or dust.** Inserting or removing the battery from the charger may ignite the dust or fumes.
- **Never force battery pack into charger. Do not modify battery pack in any way to fit into a non-compatible charger as battery pack may rupture, causing serious personal injury.**
- Charge the battery packs only in STANLEY FATMAX chargers.
- **DO NOT splash or immerse in water or other liquids.**
- **Do not store or use the tool and battery pack in locations where the temperature may fall below 4 °C (39.2 °F) (such as outside sheds or metal buildings in winter), or reach or exceed 40 °C (104 °F) (such as outside sheds or metal buildings in summer).**
- **Do not incinerate the battery pack even if it is severely damaged or is completely worn out.** The battery pack can

explode in a fire. Toxic fumes and materials are created when lithium-ion battery packs are burned.

- **If battery contents come into contact with the skin, immediately wash area with mild soap and water.** If battery liquid gets into the eye, rinse water over the open eye for 15 minutes or until irritation ceases. If medical attention is needed, the battery electrolyte is composed of a mixture of liquid organic carbonates and lithium salts.
- **Contents of opened battery cells may cause respiratory irritation.** Provide fresh air. If symptoms persist, seek medical attention.



**WARNING: Burn hazard.** Battery liquid may be flammable if exposed to spark or flame.



**WARNING: Never attempt to open the battery pack for any reason.** If battery pack case is cracked or damaged, do not insert into charger. Do not crush, drop or damage battery pack. Do not use a battery pack or charger that has received a sharp blow, been dropped, run over or damaged in any way (i.e., pierced with a nail, hit with a hammer, stepped on). Electric shock or electrocution may result. Damaged battery packs should be returned to service centre for recycling.



**WARNING: Fire hazard. Do not store or carry the battery pack so that metal objects can contact exposed battery terminals.** For example, do not place the battery pack in aprons, pockets, tool boxes, product kit boxes, drawers, etc., with loose nails, screws, keys, etc.



**CAUTION: When not in use, place tool on its side on a stable surface where it will not cause a tripping or falling hazard.** Some tools with large battery packs will stand upright on the battery pack but may be easily knocked over.

### Transportation



**WARNING: Fire hazard.** Transporting batteries can possibly cause fire if the battery terminals inadvertently come into contact with conductive materials. When transporting batteries, make sure that the battery terminals are protected and well-insulated from materials that could contact them and cause a short circuit. **NOTE:** Lithium-ion batteries should not be put in checked baggage.

STANLEY FATMAX batteries comply with all applicable shipping regulations as prescribed by industry and legal standards, which include UN Recommendations on the Transport of Dangerous Goods; International Air Transport Association (IATA) Dangerous Goods Regulations; International Maritime Dangerous Goods (IMDG) Regulations; and the European Agreement Concerning The International Carriage of Dangerous Goods by Road (ADR). Lithium-ion cells and batteries have been tested to section 38.3 of the UN Recommendations on the Transport of Dangerous Goods Manual of Tests and Criteria.

In most instances, shipping a STANLEY FATMAX battery pack will be excepted from being classified as a fully regulated Class 9 Hazardous Material. In general, only shipments containing a lithium-ion battery with an energy rating greater than 100 Watt Hours (Wh) will require being shipped as fully regulated Class 9.

All lithium-ion batteries have the Wh rating marked on the pack. Furthermore, due to regulation complexities, STANLEY FATMAX does not recommend air shipping lithium-ion battery packs alone regardless of Wh rating. Shipments of tools with batteries (combo kits) can be air shipped as excepted if the Wh rating of the battery pack is no greater than 100 Wh.

Regardless of whether a shipment is considered excepted or fully regulated, it is the shipper's responsibility to consult the latest regulations for packaging, labeling/marketing and documentation requirements.

The information provided in this section of the manual is provided in good faith and believed to be accurate at the time the document was created. However, no warranty, expressed or implied, is given. It is the buyer's responsibility to ensure that its activities comply with the applicable regulations.









**Storage Recommendations**

1. The best storage place is one that is cool and dry away from direct sunlight and excessive heat or cold. For optimum battery performance and life, store battery packs at room temperature when not in use.
2. For long storage, it is recommended to store a fully charged battery pack in a cool, dry place out of the charger for optimal results.

**NOTE:** Battery packs should not be stored completely depleted of charge. The battery pack will need to be recharged before use.

**Labels on Charger and Battery Pack**

In addition to the pictographs used in this manual, the labels on the charger and the battery pack may show the following pictographs:

-  Read instruction manual before use.
-  Refer to **Technical Data** for charging time.
-  Do not probe with conductive objects.
-  Do not charge damaged battery packs.
-  Do not expose to water.
-  Have defective cords replaced immediately.
-  Charge only between 4 °C and 40 °C.
-  Only for indoor use.
-  Discard the battery pack with due care for the environment.



Charge battery packs only with designated STANLEY FATMAX chargers. Charging battery packs other than the designated STANLEY FATMAX batteries with a STANLEY FATMAX charger may make them burst or lead to other dangerous situations.



Do not incinerate the battery pack.

**Battery Type**

The following tools operate on an 18 volt battery pack: SFMCM300.

These battery packs may be used: SFMCB201, SFMCB202, SFMCB204, SFMCB206. Refer to **Technical Data** for more information.

**Package Contents**

The SFMCM300 package contains:





- 1 Cutoff Tool
- 1 Dustport Adaptor
- 1 76 mm Bonded Reinforced Wheel
- 1 76 mm Diamond Multi-Material Wheel
- 1 Arbor Adaptor
- 1 Hex Wrench
- 1 Instruction manual
- 2 Batteries (D2 models only)
- 1 Charger (D2 models only)

**NOTE:** Battery packs, chargers and kitboxes are not included with B models.

- Check for damage to the tool, parts or accessories which may have occurred during transport.
- Take the time to thoroughly read and understand this manual prior to operation.

**Markings on Tool**

The following pictograms may be shown on the tool:

-  Read instruction manual before use.
-  Wear ear protection.
-  Wear eye protection.
-  Visible radiation. Do not stare into light.

**R** ←  → **F** Icon order : Reverse/lock/forward

**Date Code Position (Fig. C)**

The production date code **30** consists of a 4-digit year followed by a 2-digit week and is extended by a 2-digit factory code.

## Description (Fig. A)



**WARNING:** Never modify the power tool or any part of it. Damage or personal injury could result.

- 1 Battery pack
- 2 Battery release button
- 3 Main handle
- 4 Variable speed trigger
- 5 Forward/reverse/lock off button
- 6 Spindle lock button
- 7 Direction indicator
- 8 Dust port adaptor
- 9 Shoe
- 10 Depth adjustment knob
- 11 Rotatable Guard
- 12 Hex wrench
- 13 LED
- 14 Accessory attachment location

## Intended Use

Your cut-off tool is designed for professional cutting applications. This cut-off tool is intended to be used to cut different materials. Follow the information regarding the application range of the cutting blade used.

**DO NOT** use under wet conditions or in the presence of flammable liquids or gases.

**DO NOT** let children come into contact with the tool. Supervision is required when inexperienced operators use this tool.

- **Young children and the infirm.** This appliance is not intended for use by young children or infirm persons without supervision.
- This product is not intended for use by persons (including children) suffering from diminished physical, sensory or mental abilities; lack of experience, knowledge or skills unless they are supervised by a person responsible for their safety. Children should never be left alone with this product.

## ASSEMBLY AND ADJUSTMENTS



**WARNING:** To reduce the risk of serious personal injury, turn tool off and disconnect battery pack before making any adjustments or removing/installing attachments or accessories. An accidental start-up can cause injury.



**WARNING:** Wheels, cutting material and metal components on the tool such as gearcase, shoe and guard may be hot during or after continued use. Use caution when approaching these areas.



**WARNING:** Use only STANLEY FATMAX batteries and chargers.

## Inserting and Removing the Battery Pack from the Tool (Fig. C)

**NOTE:** Make sure your battery pack 1 is fully charged.

### To Install the Battery Pack into the Tool Handle

1. Align the battery pack with the rails inside the tool's handle (Fig. C).
2. Slide it into the handle until the battery pack is firmly seated in the tool and ensure that you hear the lock snap into place.

### To Remove the Battery Pack from the Tool

1. Press the battery release button 2 and firmly pull the battery pack out of the tool handle.
2. Insert battery pack into the charger.

## Fuel Gauge Battery Packs (Fig. B)

Some STANLEY FATMAX battery packs include a fuel gauge, which consists of three green LED lights that indicate the level of charge remaining in the battery pack.

To actuate the fuel gauge, press and hold the fuel gauge button 29. A combination of the three green LED lights will illuminate, designating the level of charge left. When the level of charge in the battery is below the usable limit, the fuel gauge will not illuminate and the battery will need to be recharged.

**NOTE:** The fuel gauge is only an indication of the charge left on the battery pack. It does not indicate tool functionality and is subject to variation based on product components, temperature and end-user application.

## Wheels



**WARNING:** To reduce the risk of injury, only use wheels that are no greater than 3" (76 mm) in diameter, have an inner diameter of 3/8" and 7/16", without cutting teeth. Thickness of wheel not to exceed 0.09" (2.2 mm). Never force a wheel onto the machine or alter the size of the arbor hole.

A dull wheel will cause slow inefficient cutting, overload the motor, could cause excessive splintering, and could increase the possibility of kickback. Please refer to the table below to determine the correct wheel for your application.

Wheel type	Application
Diamond** Multi-Material Wheel	Drywall, fiber cement, plastic, steel, non-ferrous materials
Bonded Reinforced Wheel	Steel, stainless steel, non-ferrous materials
Diamond** Tile Wheel	Ceramic Tile, Porcelain and Granite/Marble/Stone

\*\*This blade uses manufactured diamonds engineered for cutting.

**NOTE:** Bonded Reinforced wheels are composed of abrasive grains which are held tightly together by a bonding agent and typically reinforced with a woven material.

## Installing/Replacing Wheels

### (Fig. A, D1, D2, J-L)



**WARNING:** Burn Hazard. Sharp parts. ALWAYS wear gloves when changing wheels. Wheels have sharp edges or may get extremely hot during operation, and may damage bare hands.



**WARNING:** To reduce the risk of injury, only use wheels that are no greater than 3" (76 mm) in diameter, have an inner diameter of 3/8" (or 7/16" if using adaptor ring), and without cutting teeth. Thickness of wheel not to exceed 0.09" (2.2 mm). Never force a wheel onto the machine or alter the size of the arbor hole.



**WARNING:** Since accessories, other than those offered by STANLEY FATMAX, have not been tested with this product, use of such accessories with this tool could be hazardous. To reduce the risk of injury, only STANLEY FATMAX recommended accessories should be used with this product.



**WARNING:** Failure to properly seat the flanges and/or wheel could result in serious injury (or damage to the tool or wheel).

1. Remove the battery pack **1**.
2. Lay unit on a firm surface, with the spindle **15** facing upward.
3. Hold spindle lock button **6** to keep the spindle from turning. Spindle threads are left hand.
4. Using supplied 6 mm hex wrench **12**, rotate clockwise to remove spindle screw **20**, outer flange **19**, and used wheel **18** if one is installed. Leave inner flange **16** in place.
 

**NOTE:** Hex wrench is magnetically secured.

**NOTE:** It is possible that the inner flange and outer flange may stick together. Be sure to keep both flanges separated during the wheel installation process. Refer to Fig. D2 showing the correct order of the flanges and wheel installed over the spindle.
5. Ensure inner flange is installed over the spindle.
 

**NOTE:** Your tool comes provided with a 7/16" arbor adaptor **17** which should only be used when installing a 7/16" wheel. The 7/16" arbor adaptor is not to be used with the wheels provided with this tool. When installing 7/16" wheels, place the 7/16" arbor adaptor over the inner flange. The 7/16" arbor adaptor will fit inside the center of the 7/16" wheel when assembled. Refer to Fig. D1.
6. Slip wheel over spindle. Make sure wheel goes over pilot diameter of inner flange.
 

**NOTE:** When installing diamond wheels, always match direction of rotation of the wheel to the desired direction of rotation of the tool.
7. Slip on outer flange with the flat side towards the wheel.
 

**NOTE:** The text "LOOSEN TIGHTEN" will be visible when installed correctly.
8. Start threading on spindle screw counterclockwise which will self align outer flange. Make sure the wheel is fitted in the correct orientation.
9. Depress and hold spindle lock button and tighten spindle screw with hex wrench. Do not overtighten spindle screw.

10. Release spindle lock button and turn wheel by hand to ensure it is properly centered. The wheel should not hit the shoe, guard or spindle screw. The spindle screw and flanges should be tight.

**NOTE:** Do not run tool with the spindle lock engaged. Always allow motor to come to a complete stop before engaging the spindle lock.

### Adjusting the Rotatable Guard Angle (Fig. E)



**WARNING:** Remove battery first. To reduce the risk of injury, ALWAYS adjust the guard to provide the best control and protection. ALWAYS wear gloves to protect your hands when adjusting the guard as the guard may get hot.



**WARNING:** Adjust the position of the guard to provide the maximum protection from loose particles and sparks thrown from the wheel.



**CAUTION:** Guard must be used with all cutting wheels.

1. Remove the battery pack **1**.
2. Grasp the rotatable guard **11** firmly and rotate until it snaps securely into one of three positions.

### Mounting, Removing the Shoe (Fig. A, H1)

Your cut off tool comes pre-assembled with the shoe **9** mounted to the rotatable guard **11**.

#### To Remove the Shoe

1. Remove the battery pack **1**.
2. Loosen the depth adjustment knob **10** counterclockwise.
3. Remove the depth adjustment knob and remove shoe from the rotatable guard.

#### To Mount the Shoe

1. Remove the battery pack.
2. Install shoe onto the back of the rotatable guard, aligning slot **28** to threaded hole **25** on guard. Refer to Fig. H1.
3. Install and rotate the depth adjustment knob clockwise to tighten.

**NOTE:** The shoe is not required for use with this tool. For best performance the shoe is recommended for more stability when cutting on a flat surface.

### Adjusting the Depth of Cut (Fig. H2)

1. Loosen the depth adjustment knob **10** and slide the shoe **9** up or down. Adjust the cutting depth to the thickness of the workpiece. Less than 1/4" of the wheel should be visible below the workpiece.
2. After depth of cut is selected tighten the depth adjustment knob.

### LED Worklight (Fig. A)

The LED worklight **13** will activate when the variable speed trigger **4** is depressed, and will automatically turn off 20 seconds after the variable speed trigger is released. If the variable trigger switch remains depressed, the LED worklight will remain on.

**NOTE:** The LED worklight is for lighting the immediate work surface and is not intended to be used as a flashlight.



## Attaching the Dust Port Adaptor (Fig. A, G)

A dust port adaptor **8** comes available for use with this tool. This accessory connects directly to the tool's rotatable guard **11**.

1. Remove the battery pack **1**.
2. Friction fit the dust port adaptor **8** onto the dust port hole **23** located near the front tip of the rotatable guard.

## Attaching an AirLock™ Compatible Dust Extractor (Fig. A, G)

### (Sold Separately)



**WARNING:** Do not use dust extraction when cutting metal. Swarf from metal cutting may be hot and may spark which can melt vacuum hoses and may cause a fire inside the vacuum.



**WARNING:** When using dust extraction, empty vacuum before work begins and often during work. Use care in disposing of dust. Materials in fine dust can be explosive.

The dust port adaptor **8** allows you to connect the tool to an external dust extractor using an AirLock™ connection system (sold separately), or a standard 32 mm dust extractor fitment. The AirLock™ allows for a fast, secure connection between the AirLock™ connector **21** and your tool's dust port adaptor.

1. Remove the battery pack **1**.
2. Ensure the collar on the AirLock™ connector is in the unlock position. (Refer to Figure G.) Align notches **22** on collar and AirLock™ connector as shown for unlock and lock positions.
3. Push the AirLock™ connector onto the connection point of the dust port adaptor. (Refer to Fig. G)
4. Rotate the collar to the locked position.

**NOTE:** The ball bearings inside collar lock into slot and secure the connection. The power tool is now securely connected to the dust extractor.

## OPERATION

### Instructions for Use



**WARNING:** Always observe the safety instructions and applicable regulations.



**WARNING:** To reduce the risk of serious personal injury, turn tool off and disconnect battery pack before making any adjustments or removing/installing attachments or accessories. An accidental start-up can cause injury.

### Proper Hand Position (Fig. F)



**WARNING:** To reduce the risk of serious personal injury, ALWAYS use proper hand position as shown.



**WARNING:** To reduce the risk of serious personal injury, ALWAYS hold securely in anticipation of a sudden reaction.



**WARNING:** Keep your free hand far from cutting action. Do not reach underneath the workpiece.

Proper hand position requires one hand on the main handle **3**.

## Variable Speed Trigger (Fig. A)

The tool is turned on and off by pulling and releasing the variable speed trigger **4**. The variable speed trigger permits speed control—the farther the trigger is depressed, the higher the speed of the tool.

## Forward/Reverse/Lock Off Button (Fig. A, I1, I2)



**CAUTION:** Before changing the position of the control button, be sure the trigger is released.

Your cut-off tool is equipped with a forward/reverse/lock off button **5**. There is a wheel direction label **24** located above the main handle **3** that will help to identify the current direction mode of the tool. Some applications or accessories may require the tool to be run in forward or reverse. When making a cut, select the direction of cut that allows the tool to be pushed away from your body. Always operate tool in correct rotation for wheel selected.

1. Forward (counterclockwise rotation) — Located on the right side of the tool near the variable speed trigger **4**, push the forward/reverse/lock off button **5** to the far left. Refer to Fig. I1. The forward direction of the wheel is also noted by the direction indicator **7** located on the rotatable guard **11**. Refer to Fig. A.
2. Reverse (clockwise rotation) — Located on the left side of the tool near the variable speed trigger **4**, push the forward/reverse/lock off button **5** to the far right. Refer to Fig. I2. The reverse direction of the wheel is also noted by the direction indicator **7** located on the rotatable guard **11**. Refer to Fig. A.
3. The center position of the forward/reverse/lock off button locks the tool in the off position. When locked the variable speed trigger cannot be depressed.

**NOTE:** Keep the button in the center locked position when the tool is not in use or when being transported.

## To Operate (Fig. A, F)



**CAUTION:** Before attempting to start, grasp tool firmly.



**WARNING:** To reduce the risk of injury, **DO NOT** use a toothed blade.



**WARNING:** This tool is intended to be used dry. If water cooling is necessary, use a spray bottle with clean water to lightly wet surface only, avoid over-wetting the workpiece. **NEVER** immerse your tool or battery pack in any liquid or allow liquid inside them.



**WARNING:** Wheels used for cutting may break or kick back if they bend or twist while the tool is being used to do cut-off work.



**WARNING:** Do not bang or bump a cut-off wheel when starting or during a cut.

1. Grasp main handle **3** firmly.
2. Line up wheel **18** with material to be cut. Be sure nothing is near or in line with the wheel.

3. Depress and hold the variable speed trigger **4**. Slowly feed the wheel into the workpiece with firm even pressure, allowing the tool to do the work. Do not force the cut off tool through the workpiece. Forcing a cut off tool can cause kickback. For maximum efficiency and wheel life, keep the wheel speed high.
4. While cutting, if using the shoe, keep the shoe against the workpiece and maintain a firm grip.  
**NOTE:** If making a partial cut, restarting a cut, or correcting cut direction, allow the wheels to come to a complete stop. To resume cutting, pull the variable speed trigger and re-enter the cut slowly.
5. To stop tool, release the variable speed trigger.

## General Tips for Cutting Materials

- For best control, user cutting direction should be opposite wheel rotation. Example: When making a cut away from user by pushing the tool forward, set wheel rotation to reverse/clockwise direction.
- Be sure that the wheel is at full speed before continuing a cut.
- Allow the wheel to come to a complete stop before raising the wheel out of the material.

## Cutting Tile

- To reduce overheating of cutting wheel or workpiece, user may lightly wet surface.
- If excessive chipping of the tile is observed, user may operate tool at slower speed using variable speed trigger to achieve a cleaner cut.
- Cutting tile will generate debris. Guard position may be adjusted to deflect debris away from user.

## Cutting Plastic

- Take frequent breaks to allow wheel to cool down.
- If melted material or debris becomes adhered to blade, shoe or guard: Release trigger. Allow unit to rest and material to cool. Remove battery. Remove debris. Ensure all areas around wheel including inside of guard is clear of debris. Resume cutting operation.

## Cutting Metals

Observe the following to avoid potential hazards when cutting metals.

- During and shortly after cutting operation the material, wheel and metal components on the tool such as gearcase, guard and shoe may get hot.
- Allow these areas to cool before touching to avoid injury.
- Cutting metal will generate sparks. Guard position may be adjusted to deflect sparks and debris away from user.
- Cutting material and cutting wheel may have sharp or jagged edges after cutting operation. Wear gloves and use caution when touching these areas.

## Transportation and Storage

During transportation and storage lock the variable speed trigger with the lock-off button. Refer to the **Forward/Reverse/Lock Off Button** section.

Remove the battery pack during the tool storage.

## MAINTENANCE

Your power tool has been designed to operate over a long period of time with a minimum of maintenance. Continuous satisfactory operation depends upon proper tool care and regular cleaning.



**WARNING:** To reduce the risk of serious personal injury, turn tool off and disconnect battery pack before making any adjustments or removing/installing attachments or accessories. An accidental start-up can cause injury.

The charger and battery pack are not serviceable.

## Lubrication

Your power tool requires no additional lubrication.

## Cleaning



**WARNING:** Electrical shock and mechanical hazard. Disconnect the electrical appliance from the power source before cleaning.



**WARNING:** To ensure safe and efficient operation, always keep the electrical appliance and the ventilation slots clean.



**WARNING:** Never use solvents or other harsh chemicals for cleaning the non-metallic parts of the tool. These chemicals may weaken the materials used in these parts. Use a cloth dampened only with water and mild soap. Never let any liquid get inside the tool; never immerse any part of the tool into a liquid.

Ventilation slots can be cleaned using a dry, soft non-metallic brush and/or a suitable vacuum cleaner. Do not use water or any cleaning solutions. Wear approved eye protection and an approved dust mask.

## Optional Accessories



**WARNING:** Since accessories, other than those offered by STANLEY FATMAX, have not been tested with this product, use of such accessories with this tool could be hazardous. To reduce the risk of injury, only STANLEY FATMAX-recommended accessories should be used with this product.



**WARNING:** Handle and store all abrasive wheels carefully to prevent damage from thermal shock, heat, mechanical damage, etc. Store in a dry protected area free from high humidity, freezing temperatures or extreme temperature changes.

Consult your dealer for further information on the appropriate accessories.

## Belt Hook (Fig. L)

### Optional accessory, sold separately.



**WARNING:** To reduce the risk of serious personal injury, turn tool off and disconnect battery pack before making any adjustments or removing/installing attachments or accessories.



**WARNING:** To reduce the risk of serious personal injury, **DO NOT** suspend tool overhead or suspend objects from the belt hook. **ONLY** hang tool's belt hook from a work belt.



**WARNING:** To reduce the risk of serious personal injury, ensure the screw holding the belt hook is secure.



**CAUTION:** To reduce the risk of personal injury or damage, **DO NOT** use the belt hook to hang the tool.

**IMPORTANT:** When attaching or replacing the belt hook **26**, use only the screw **27** that is provided. Be sure to securely tighten screw.

If the belt hook is not desired at all, it can be removed from the tool.

1. Place the belt hook onto the accessory attachment location **14** at the base of the tool.
2. Use a screwdriver to secure the belt hook with the provided screw. Do not use any other screw for this.

To remove the belt hook, remove the screw that holds the belt hook in place.

## Protecting the Environment



Separate collection. Products and batteries marked with this symbol must not be disposed of with normal household waste.

Products and batteries contain materials that can be recovered or recycled, reducing the demand for raw materials. Please recycle electrical products and batteries according to local provisions. Further information is available at [www.2helpU.com](http://www.2helpU.com).

## Rechargeable Battery Pack

This long-life battery pack must be recharged when it fails to produce sufficient power on jobs that were easily done before. At the end of its technical life, discard it with due care for our environment:

- Run the battery pack down completely, then remove it from the tool.
- Li-Ion cells are recyclable. Take them to your dealer or a local recycling station. The collected battery packs will be recycled or disposed of properly.

COMPATIBLE BATTERIES	V <sub>DC</sub>	Ah	Weight (kg)	COMPATIBLE CHARGERS			
				SFMCB10	SFMCB11	SFMCB12	SFMCB14
SFMCB201	18	1.5	0.4	✓	✓	✓	
SFMCB202	18	2.0	0.4	✓	✓	✓	✓
SFMCB204	18	4.0	0.6	✓	✓	✓	✓
SFMCB206	18	6.0	0.9	✓	✓	✓	✓

<b>Australia &amp; New Zealand</b>	Stanley Fat Max 810 Whitehorse Road Box Hill VIC 3128, Australia	Tel. 1800 338 002 Tel. 0800 339 258 (NZ) <a href="http://www.stanleytools.com.au">www.stanleytools.com.au</a> / <a href="http://www.stanleytools.co.uk">www.stanleytools.co.uk</a> (NZ)
<b>België/Belgique</b>	Stanley Fat Max Egide Walschaertstraat 14-16 2800 Mechelen Belgium	De. Tel. +32 70 220 065 Fr. Tel. +32 70 220 066 Fax +32 15 473 799 <a href="http://www.stanleytools.eu">www.stanleytools.eu</a> / <a href="mailto:Enduser.be@SBDinc.com">Enduser.be@SBDinc.com</a>
<b>Danmark</b>	Stanley Fat Max Farveland 1B 2600 Glostrup	Tel. 70 20 15 10 Fax 70 22 49 10 <a href="http://www.stanleyworks.dk">www.stanleyworks.dk</a>
<b>Deutschland</b>	Stanley Fat Max Richard Klinger Str. 11, D - 65510 Idstein	Tel. 06126 21-1 Fax 06126 21-2770
<b>Ελλάδα</b>	Stanley Fat Max. Στραβωνος 7 & Λεωφ. Βουλιαμενης 159 Γλυφάδα 166 74 - Αθήνα	Τηλ. +30 210 8981-616 Φαξ +30 210 8983-285 <a href="http://www.stanleyworks.gr">www.stanleyworks.gr</a>
<b>España</b>	Stanley Fat Max. Parc de Negocis "Mas Blau" Edificio Muntadas, c/Bergadá, 1, Of. A6 08820 El Prat de Llobregat (Barcelona)	Tel. 934 797 400 Fax 934 797 419 <a href="mailto:respuesta.postventa@sbdinc.com">respuesta.postventa@sbdinc.com</a> / <a href="http://www.stanleyworks.es">www.stanleyworks.es</a>
<b>France</b>	Stanley Fat Max 62 Chemin de la Bruyère 69570 Dardilly, France	Tel. 04 72 20 39 20 Fax 04 72 20 39 00 <a href="http://www.stanleyoutillage.fr">www.stanleyoutillage.fr</a>
<b>Helvetia</b>	Stanley Fat Max In der Luberzen 40 8902 Urdorf	Tel. 01 730 67 47 Fax 01 730 70 67 <a href="http://www.stanleyworks.de">www.stanleyworks.de</a>
<b>Italia</b>	Stanley Fat Max Energypark-Building 03 sud, Via Monza 7/A 20871 Vimercate (MB)	Tel. 039-9590200 Fax 039-9590313 <a href="http://www.stanley.it">www.stanley.it</a>
<b>Nederland</b>	Stanley Fat Max Joulehof 12, 4600 RG Bergen op Zoom	Tel. +31 164 283 065 Fax +31 164 283 200 <a href="mailto:Enduser.NL@SBDinc.com">Enduser.NL@SBDinc.com</a>
<b>Norge</b>	Stanley Fat Max Postboks 4613, Nydalen 0405 Oslo	Tif. 45 25 13 00 Fax 45 25 08 00
<b>Österreich</b>	Stanley Fat Max Oberlaaerstraße 248, A-1230 Wien	Tel. 01 66116-0 Fax 01 66116-614 <a href="http://www.stanleyworks.de">www.stanleyworks.de</a>
<b>Portugal</b>	Stanley Fat Max Centro de Escritórios de Sintra Avenida Almirante Gago Coutinho, 132/134, Edifício 142710-418 Sintra 2710-418 Lisboa	Tel. 214667500 Fax 214667575 <a href="mailto:resposta.posvenda@sbdinc.com">resposta.posvenda@sbdinc.com</a>
<b>Suomi</b>	Stanley Fat Max Tekniikantie 12, 02150 Espoo	Puh. 010 400 430 Faksi 0800 411 340 <a href="http://www.stanleyworks.fi">www.stanleyworks.fi</a>
<b>Sverige</b>	Stanley Fat Max Box 94, 431 22 Mölndal	Tel. 031-68 61 00 Fax 031-68 60 08
<b>Türkiye</b>	Stanley Black & Decker Turkey Alet Üretim Tic. Ltd.Şti. Hçerenköy Mahallesi Umut Sokak. No: 10--12 / 82--83--84 Kat: 19 Ataşehir-İstanbul, Türkiye	Puh. +90 216 665 2900 Faks +90 216 665 2901 <a href="https://tr.stanleytools.global">https://tr.stanleytools.global</a> <a href="mailto:info-tr@sbdinc.com">info-tr@sbdinc.com</a>
<b>United Kingdom</b>	Stanley Fat Max Spennymoor DL16 6YJ, England	Tel. +44 (0)1753 511234 Fax +44 (0)1753 551155 <a href="http://www.stanleytools.co.uk">www.stanleytools.co.uk</a>
<b>Middle East &amp; Africa</b>	Stanley Fat Max P.O.Box - 17164 Jebel Ali (South Zone), Dubai, UAE	Tel. +971 4 8127400 Fax +971 4 8127036 <a href="http://www.stanleyworks.ae">www.stanleyworks.ae</a>