

DEWALT®

D25032

D25033

D25133

D25134

D25143

D25144

www.DEWALT.com

Fig. A

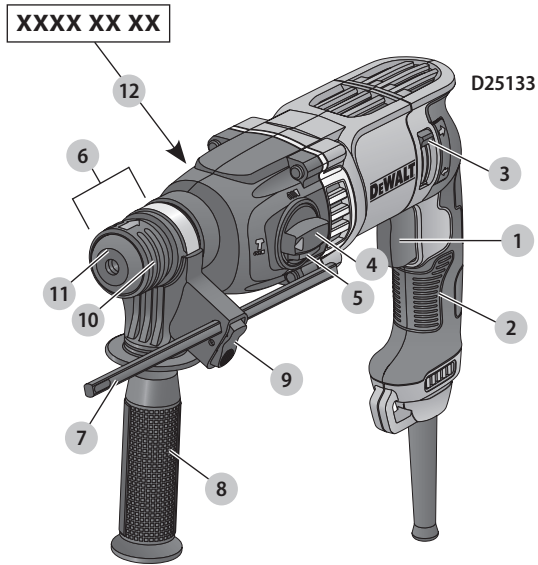

Fig. B

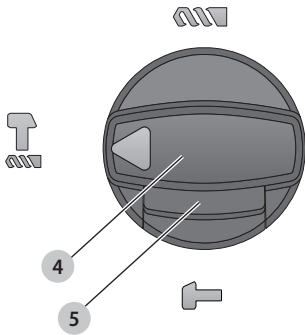

Fig. C

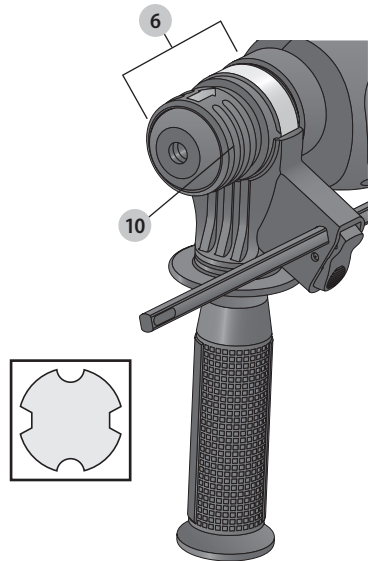

Fig. D

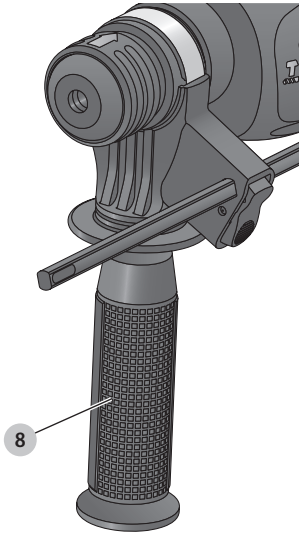

Fig. E

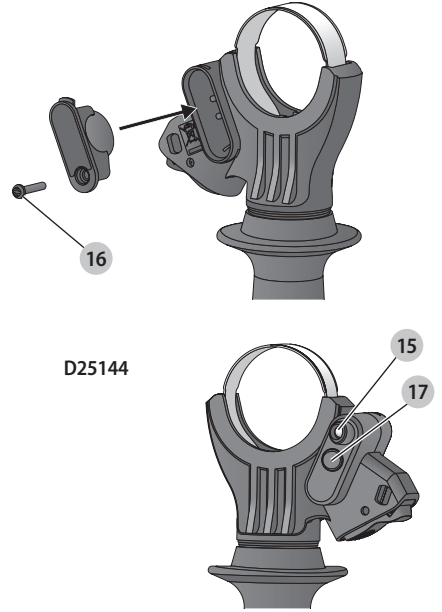

Fig. F

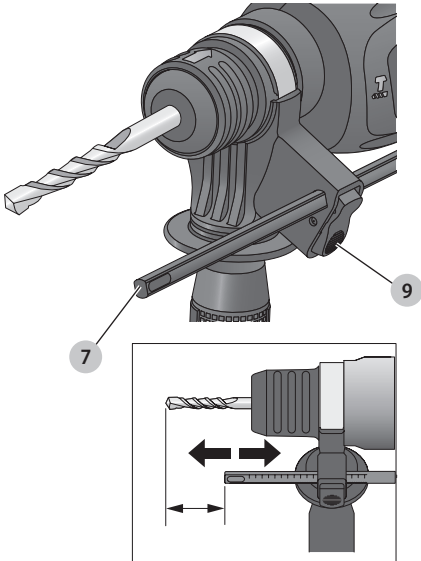

Fig. G

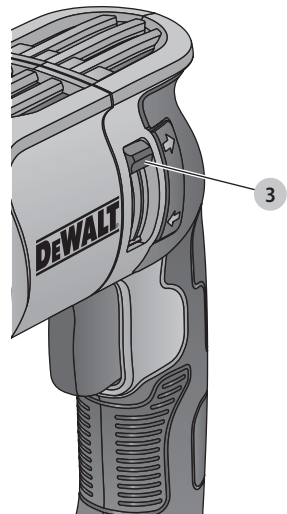

Fig. H

D25134
D25144

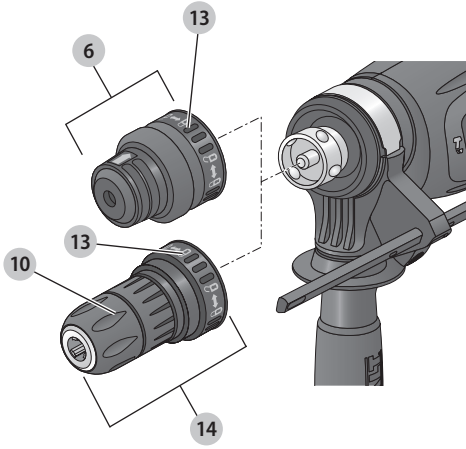
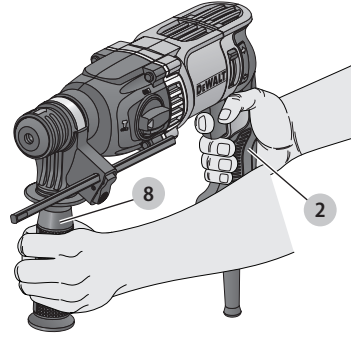

Fig. I



ROTARY HAMMER DRILL

D25032, D25033, D25133, D25134, D25143, D25144

Congratulations!

You have chosen a DEWALT tool. Years of experience, thorough product development and innovation make DEWALT one of the most reliable partners for professional power tool users.

Technical Data

		D25032	D25033	D25133	D25134	D25143	D25144
Voltage	V	230	230	230	230	230	230
(UK & Ireland only)		230/115	230/115	230/115	230/115	230/115	230/115
Type		1/10	1/10	1/10	1/10	1	1/10
Frequency	Hz	50	50	50	50	50	50
Power input	W	710	710	800	800	900	900
No-load speed	min ⁻¹	0–1550	0–1550	0–1500	0–1500	0–1450	0–1450
No-load beats per min	bpm	0–5680	0–5680	0–5500	0–5540	0–5350	0–5350
Single impact energy (EPTA 05/2009)	J	2.0	2.0	2.6	2.8	3.0	3.0
Maximum drilling range in steel/wood/concrete	mm	13/30/22	13/30/22	13/30/26	13/30/26	13/30/28	13/30/28
Chisel positions		—	44	44	48	48	48
Core drilling capacity in soft brick	mm	50	50	50	65	65	65
Tool holder		SDS plus®	SDS plus®	SDS plus®	SDS plus®	SDS plus®	SDS plus®
Collar diameter	mm	43	43	43	54	54	54
Weight	kg	2.5	2.5	2.6	3.0	3.1	3.1
Noise values and vibration values (triax vector sum) according to EN IEC 62841-2-6:							
L _{PA} (emission sound pressure level)	dB(A)	91	91	92	93	92	92
L _{WA} (sound power level)	dB(A)	99	99	100	101	100	100
K _{WA} (uncertainty for the given sound level)	dB(A)	3	3	3	3	3	3
Drilling into concrete							
Vibration emission value a _{h,HD} =	m/s ²	14.9	14.9	16	18.1	17.3	17.3
Uncertainty K =	m/s ²	1.5	1.5	1.5	1.5	1.5	1.5
Chiselling							
Vibration emission value a _{h,Cheq} =	m/s ²	—	15.3	15.4	17.4	16.5	16.5
Uncertainty K =	m/s ²	—	1.5	1.5	1.5	1.5	1.5

The vibration and/or noise emission level given in this information sheet has been measured in accordance with a standardised test given in EN IEC 62841 and may be used to compare one tool with another. It may be used for a preliminary assessment of exposure.



WARNING: The declared vibration and/or noise emission level represents the main applications of the tool. However, if the tool is used for different applications, with different accessories or is poorly maintained, the vibration and/or noise emission may differ. This may significantly increase the exposure level over the total working period.

An estimation of the level of exposure to vibration and/or noise should also take into account the times when the tool is switched off or when it is running but not actually doing the

job. This may significantly reduce the exposure level over the total working period.

Identify additional safety measures to protect the operator from the effects of vibration and/or noise such as: maintain the tool and the accessories, keep the hands warm (relevant for vibration), organisation of work patterns.

EC-Declaration of Conformity

Machinery Directive



Rotary Hammer Drill

**D25032, D25033, D25133, D25134,
D25143, D25144**

DEWALT declares that these products described under

Technical Data are in compliance with:
2006/42/EC, EN 62841-1:2015+A11:2022,
EN IEC 62841-2-6:2020 + A11:2020.

These products also comply with Directive 2014/30/EU and
2011/65/EU. For more information, please contact DEWALT at
the following address or refer to the back of the manual.

The undersigned is responsible for compilation of the technical
file and makes this declaration on behalf of DEWALT.

Markus Rompel
Director Engineering
DEWALT, Richard-Klinger-Straße 11,
65510, Idstein, Germany
24.02.2023

DECLARATION OF CONFORMITY THE SUPPLY OF MACHINERY (SAFETY) REGULATIONS 2008



Rotary Hammer Drill

D25032, D25033, D25133, D25134, D25143, D25144

DEWALT declares that these products described under
Technical Data are in compliance with:

The Supply of Machinery (Safety) Regulations, 2008, S.I.
2008/1597 (as amended),

BS EN 62841-1:2015+A11:2022, BS EN IEC 62841-2-6:2020
+ A11:2020. These products conform to the following UK
Regulations:

Electromagnetic Compatibility Regulations, 2016, S.I.2016/1091
(as amended).

The Restriction of the Use of Certain Hazardous Substances
in Electrical and Electronic Equipment Regulations 2012, S.I.
2012/3032 (as amended).

For more information, please contact DEWALT at the following
address or refer to the back of the manual.

The undersigned is responsible for compilation of the technical
file and makes this declaration on behalf of DEWALT.

Karl Evans
Vice President Professional Power Tools EANZ GTS
DEWALT UK, 270 Bath Road, Slough
Berkshire, SL1 4DX
England
24.02.2023



WARNING: To reduce the risk of injury, read the
instruction manual.

Definitions: Safety Guidelines

The definitions below describe the level of severity for each signal
word. Please read the manual and pay attention to these symbols.



DANGER: Indicates an imminently hazardous
situation which, if not avoided, **will** result in **death or
serious injury**.



WARNING: Indicates a potentially hazardous situation
which, if not avoided, **could** result in **death or
serious injury**.



CAUTION: Indicates a potentially hazardous situation
which, if not avoided, **may** result in **minor or
moderate injury**.

NOTICE: Indicates a practice **not related to
personal injury** which, if not avoided, **may** result in
property damage.



Denotes risk of electric shock.



Denotes risk of fire.

General Power Tool Safety Warnings



WARNING: Read all safety warnings, instructions,
illustrations and specifications provided with this
power tool. Failure to follow all instructions listed below
may result in electric shock, fire and/or serious injury.

SAVE ALL WARNINGS AND INSTRUCTIONS FOR FUTURE REFERENCE

The term "power tool" in the warnings refers to your mains-operated
(corded) power tool or battery-operated (cordless) power tool.

1) Work area safety

- Keep work area clean and well lit.** Cluttered or dark
areas invite accidents.
- Do not operate power tools in explosive
atmospheres, such as in the presence of flammable
liquids, gases or dust.** Power tools create sparks which
may ignite the dust or fumes.
- Keep children and bystanders away while operating
a power tool.** Distractions can cause you to lose control.

2) Electrical safety

- a) **Power tool plugs must match the outlet. Never modify the plug in any way. Do not use any adapter plugs with earthed (grounded) power tools.** *Unmodified plugs and matching outlets will reduce risk of electric shock.*
- b) **Avoid body contact with earthed or grounded surfaces such as pipes, radiators, ranges and refrigerators.** *There is an increased risk of electric shock if your body is earthed or grounded.*
- c) **Do not expose power tools to rain or wet conditions.** *Water entering a power tool will increase the risk of electric shock.*
- d) **Do not abuse the cord. Never use the cord for carrying, pulling or unplugging the power tool. Keep cord away from heat, oil, sharp edges or moving parts.** *Damaged or entangled cords increase the risk of electric shock.*
- e) **When operating a power tool outdoors, use an extension cord suitable for outdoor use.** *Use of a cord suitable for outdoor use reduces the risk of electric shock.*
- f) **If operating a power tool in a damp location is unavoidable, use a residual current device (RCD) protected supply.** *Use of an RCD reduces the risk of electric shock.*

3) Personal safety

- a) **Stay alert, watch what you are doing and use common sense when operating a power tool. Do not use a power tool while you are tired or under the influence of drugs, alcohol or medication.** *A moment of inattention while operating power tools may result in serious personal injury.*
- b) **Use personal protective equipment. Always wear eye protection.** *Protective equipment such as dust mask, non-skid safety shoes, hard hat, or hearing protection used for appropriate conditions will reduce personal injuries.*
- c) **Prevent unintentional starting. Ensure the switch is in the off position before connecting to power source and/or battery pack, picking up or carrying the tool.** *Carrying power tools with your finger on the switch or energising power tools that have the switch on invites accidents.*
- d) **Remove any adjusting key or wrench before turning the power tool on.** *A wrench or a key left attached to a rotating part of the power tool may result in personal injury.*
- e) **Do not overreach. Keep proper footing and balance at all times.** *This enables better control of the power tool in unexpected situations.*
- f) **Dress properly. Do not wear loose clothing or jewellery. Keep your hair, clothing and gloves away from moving parts.** *Loose clothes, jewellery or long hair can be caught in moving parts.*
- g) **If devices are provided for the connection of dust extraction and collection facilities, ensure these are connected and properly used.** *Use of dust collection can reduce dust-related hazards.*

4) Power tool use and care

- a) **Do not force the power tool. Use the correct power tool for your application.** *The correct power tool will do the job better and safer at the rate for which it was designed.*
- b) **Do not use the power tool if the switch does not turn it on and off.** *Any power tool that cannot be controlled with the switch is dangerous and must be repaired.*
- c) **Disconnect the plug from the power source and/or the battery pack from the power tool before making any adjustments, changing accessories, or storing power tools.** *Such preventive safety measures reduce the risk of starting the power tool accidentally.*
- d) **Store idle power tools out of the reach of children and do not allow persons unfamiliar with the power tool or these instructions to operate the power tool.** *Power tools are dangerous in the hands of untrained users.*
- e) **Maintain power tools. Check for misalignment or binding of moving parts, breakage of parts and any other condition that may affect the power tool's operation. If damaged, have the power tool repaired before use.** *Many accidents are caused by poorly maintained power tools.*
- f) **Keep cutting tools sharp and clean.** *Properly maintained cutting tools with sharp cutting edges are less likely to bind and are easier to control.*
- g) **Use the power tool, accessories and tool bits etc., in accordance with these instructions taking into account the working conditions and the work to be performed.** *Use of the power tool for operations different from those intended could result in a hazardous situation.*

5) Service

- a) **Have your power tool serviced by a qualified repair person using only identical replacement parts.** *This will ensure that the safety of the power tool is maintained.*

Hammer Safety Warnings

- **Wear ear protectors.** *Exposure to noise can cause hearing loss.*
- **Use auxiliary handle(s) if supplied with the tool.** *Loss of control can cause personal injury.*
- **Hold the power tool by insulated gripping surfaces, when performing an operation where the cutting accessory may contact hidden wiring or its own cord.** *Cutting accessory contacting a "live" wire may make exposed metal parts of the power tool "live" and could give the operator an electric shock.*

Safety Instructions When Using Long Drill Bits with Rotary Hammers

- **Always start drilling at low speed and with the bit tip in contact with the workpiece.** *At higher speeds, the bit is likely to bend if allowed to rotate freely without contacting the workpiece, resulting in personal injury.*
- **Apply pressure only in direct line with the bit and do not apply excessive pressure.** *Bits can bend causing breakage or loss of control, resulting in personal injury.*

Additional Safety Instructions for Rotary Hammer Drills

- **Use clamps or other practical way to secure and support the workpiece to a stable platform.** Holding the work by hand or against your body is unstable and may lead to loss of control.
- **Wear safety goggles or other eye protection.** Hammering operations cause chips to fly. Flying particles can cause permanent eye damage. Wear a dust mask or respirator for applications that generate dust. Ear protection may be required for most applications.
- **Keep a firm grip on the tool at all times.** Do not attempt to operate this tool without holding it with both hands. It is recommended that the side handle be used at all times. Operating this tool with one hand will result in loss of control. Breaking through or encountering hard materials such as re-bar may be hazardous as well. Tighten the side handle securely before use.
- **Do not operate this tool for long periods of time.** Vibration caused by hammer action may be harmful to your hands and arms. Use gloves to provide extra cushion and limit exposure by taking frequent rest periods.
- **Do not recondition bits yourself.** Bit reconditioning should be done by a qualified specialist. Improperly reconditioned bits could cause injury. Only slightly-worn chisels can be resharpened by grinding.
- **Do not overheat the bit (discoloration) while grinding a new edge.** Badly worn chisels require reforging. Do not reharden and temper the chisel.
- **Wear gloves when operating tool or changing bits.** Accessible metal parts on the tool and bits may get extremely hot during operation. Small bits of broken material may damage bare hands.
- **Never lay the tool down until the bit has come to a complete stop.** Moving bits could cause injury.
- **Do not strike jammed bits with a hammer to dislodge them.** Fragments of metal or material chips could dislodge and cause injury.
- **Be certain that the material being drilled does not conceal electric or gas service and that their locations have been verified with the utility companies.**
- **Keep the power cord away from the rotating bit.** Do not wrap the cord around any part of your body. An electric cord wrapped around a spinning bit may cause personal injury and loss of control.
- **When working above the floor, make sure that the area below is clear.** Falling parts can cause injuries to bystanders.

Reducing of Dust Exposure

Before starting work, check the hazard class of the dust that will be produced when working.



WARNING: Dust can be harmful to health. Touching or breathing of some dust created during the work process by using a power tool and other construction activities contains chemicals, minerals or particles known to

cause respiratory infections, allergic reactions, cancer, birth defects or other reproductive harm of the user or bystanders.

- Such dusts can be generated, for example, when working on hardwoods such as beech or oak, lead-based paint, on concrete, masonry or stones containing quartz.
- Material containing asbestos may be handled only by specialists.
- Observe the relevant regulations in your country for the materials to be worked on.
- Use a dust extractor or extraction system with an officially approved protection class in compliance with the locally applicable dust protection regulations and suitable for the material to be worked on.
- Capture the resulting dust particles directly at the source and avoid deposits in the surrounding area. Use suitable extraction accessories for this purpose.

Additional measures:

- Make sure that the workplace is well ventilated.
- Wear a respirator appropriate for the type of dust generated.

Residual Risks

In spite of the application of the relevant safety regulations and the implementation of safety devices, certain residual risks cannot be avoided. These are:

- Impairment of hearing.
- Risk of personal injury due to flying particles.
- Risk of burns due to accessories becoming hot during operation.
- Risk of personal injury due to prolonged use.

Electrical Safety

The electric motor has been designed for one voltage only. Always check that the power supply corresponds to the voltage on the rating plate.



Your DeWALT tool is double insulated in accordance with EN62841; therefore no earth wire is required.



WARNING: 115V units have to be operated via a fail-safe isolating transformer with an earth screen between the primary and secondary winding.

If the supply cord is damaged, it must be replaced by a specially prepared cord available through the DeWALT service organisation.

Mains Plug Replacement (U.K. & Ireland Only)

If a new mains plug needs to be fitted:

- Safely dispose of the old plug.
- Connect the brown lead to the live terminal in the plug.
- Connect the blue lead to the neutral terminal.



WARNING: No connection is to be made to the earth terminal.

Follow the fitting instructions supplied with good quality plugs. Recommended fuse: 13 A.

Using an Extension Cable

An extension cord should not be used unless absolutely necessary. Use an approved extension cable suitable for the power input of your charger (see **Technical Data**). The minimum conductor size is 1.5 mm²; the maximum length is 30 m.

When using a cable reel, always unwind the cable completely.

Package Contents

The package contains:

- 1 Rotary hammer drill
- 1 Side handle
- 1 Depth adjustment rod
- 1 Keyless chuck (D25134, D25144)
- 1 Instruction manual
- Check for damage to the tool, parts or accessories which may have occurred during transport.
- Take the time to thoroughly read and understand this manual prior to operation.

Markings on Tool

The following pictograms are shown on the tool:



Read instruction manual before use.



Wear ear protection.



Wear eye protection.



Visible radiation. Do not stare into light.

Date Code Position (Fig. A)

The production date code **12** consists of a 4-digit year followed by a 2-digit week and is extended by a 2-digit factory code.

Description (Fig. A, E, H)



WARNING: Never modify the power tool or any part of it. Damage or personal injury could result.

- 1 Variable speed switch
- 2 Main handle
- 3 Forward/Reverse lever
- 4 Mode selector switch
- 5 Mode selector button
- 6 SDS plus® tool holder
- 7 Depth adjustment rod
- 8 Side handle
- 9 Depth rod button
- 10 Locking sleeve
- 11 Dust cover
- 12 Date code
- 13 Locking collar (D25134, D25144)
- 14 Keyless chuck (D25134, D25144)

15 Side handle worklight (D25144)

16 Battery door screw (D25144)

17 On/off light button (D25144)

Intended Use

The D25032 rotary hammer drill has been designed for professional drilling, hammerdrilling, and screwdriving. The D25033, D25133, D25134, D25143 and D25144 rotary hammer drills have been designed for professional drilling, hammerdrilling, screwdriving and light chipping.

DO NOT use under wet conditions or in the presence of flammable liquids or gases.

These hammerdrills are professional power tools.

DO NOT let children come into contact with the tool.

Supervision is required when inexperienced operators use this tool.

- **Young children and the infirm.** This appliance is not intended for use by young children or infirm persons without supervision.
- This product is not intended for use by persons (including children) suffering from diminished physical, sensory or mental abilities; lack of experience, knowledge or skills unless they are supervised by a person responsible for their safety. Children should never be left alone with this product.

Torque Limiting Clutch

All rotary hammer drills are equipped with a torque limiting clutch that reduces the maximum torque reaction transmitted to the operator in case of jamming of a drill bit. This feature also prevents the gearing and electric motor from stalling. The torque limiting clutch has been factory-set and cannot be adjusted.

ASSEMBLY AND ADJUSTMENTS



WARNING: To reduce the risk of serious personal injury, turn tool off and disconnect tool from power source before making any adjustments or removing/installing attachments or accessories. Be sure the trigger switch is in the OFF position. An accidental start-up can cause injury.

Selecting the Operating Mode (Fig. B)

The tool can be used in the following operating modes:



Rotary drilling: for screwdriving and for drilling into steel, wood and plastics.



Hammerdrilling: for concrete and masonry drilling operations.

Bit rotation: non-working position used only to rotate a flat chisel into the desired position.



Hammering only (D25033, D25133, D25134, D25143, D25144): for light chipping, chiselling and demolition applications. In this mode the tool can also be used as a lever to free a jammed drill bit.

1. To select the operating mode, press the mode selector button **5** and rotate the mode selector switch **4** until it points to the symbol of the required mode.
2. Release the mode selector button and check that the mode selector switch is locked in place.

 **WARNING:** Do not select the operating mode when the tool is running.

Indexing the Chisel Position (Fig. B)

The chisel can be indexed and locked into different positions.

1. Press the mode selector button **5** and rotate the mode selector switch **4** until it points to the “bit rotation/hammerdrilling” position.
2. Rotate the chisel to the desired position.
3. Set the mode selector switch **4** to the “hammering only” position.
4. Twist the chisel until it locks in position.

Inserting and Removing SDS plus® Accessories (Fig. C)

This tool uses SDS plus® accessories (refer to the inset in Fig. C for a cross-section of an SDS plus® bit shank). We recommend using professional accessories only.

1. Clean and grease the bit shank.
2. Insert the bit shank into the SDS plus® tool holder **6**.
3. Push the bit down and turn it slightly until it fits into the slots.
4. Pull on the bit to check if it is properly locked. The hammering function requires the bit to be able to move axially several centimetres when locked in the tool holder.
5. To remove a bit, pull back the locking sleeve **10** and pull out the bit.

 **WARNING:** Always wear gloves when you change accessories. The exposed metal parts on the tool and accessory may become extremely hot during operation.

Fitting the Side Handle (Fig. D)

The side handle **8** can be fitted to suit both right-handed and left-handed users.

 **WARNING:** Do not use the tool without the side handle properly assembled.

1. Loosen the side handle.
2. **For right-handed users:** Slide the side handle clamp over the collar behind the tool holder, handle at the left.
For left-handed users: Slide the side handle clamp over the collar behind the tool holder, handle at the right.
3. Rotate the side handle to the desired position and tighten the handle.

Side Handle Worklight (Fig. E)

D25144

The side handle on the D25144 has a worklight **15**. The light is battery powered and operated by using the on/off button **17**.

To replace the worklight's batteries (CR2032 x 2):

1. Remove battery door screw **16** as shown in Figure E.

2. Replace the battery with the positive face pointing outwards.
3. Close the battery compartment and secure the screw.

Setting the Drilling Depth (Fig. F)

1. Insert the required drill bit as described above.
2. Press the depth rod button **9** and keep it depressed.
3. Fit the depth adjustment rod **7** through the hole in the depth stop clamp.
4. Adjust the drilling depth as shown.
5. Release the depth stop clamp.

Reversing Lever (Fig. G)

The forward/reverse lever **3** is used to reverse the rotation of the hammer for backing out fasteners or jammed bits in the drill-only function.

 **CAUTION:** When reversing to clear jammed bits, be ready for strong reactive torque.

To reverse the hammer, turn it off and align the forward/reverse lever **3** with the yellow arrow pointing backward.

To position the lever for forward operation, turn the hammer off and align the forward/reverse lever **3** with the yellow arrow pointing forward.

Fitting the Chuck Adapter and Chuck

Optional Accessory

D25032, D25033, D25133, D25143

1. Screw the chuck onto the threaded end of the chuck adapter.
2. Insert the connected chuck and adapter in the tool as though it were a standard SDS plus® bit.
3. To remove the chuck, proceed as for removing a standard SDS plus® bit.

 **WARNING:** Never use standard chucks in the hammerdrilling mode.

Replacing the SDS plus® Tool Holder with the Keyless Chuck (Fig. H)

D25134, D25144

1. Turn the locking collar **13** into the unlocking position and pull the SDS plus® tool holder **6** off.
2. Push the keyless chuck **14** onto the spindle and turn the locking collar **13** to the locking position.

To replace the keyless chuck with the SDS plus® tool holder, first remove the keyless chuck the same way the tool holder was removed. Then place the tool holder the same way the keyless chuck was placed, making sure to turn the locking collar to the locking position.

 **WARNING:** Never use standard chucks in the hammerdrilling mode.

Replacing the Dust Cover (Fig. A)

The dust cover **11** prevents dust ingress into the mechanism. Replace a worn dust cover immediately.

1. Pull back the locking sleeve **10** and pull the dust cover **11** off.
2. Fit the new dust cover.
3. Release the locking sleeve.

OPERATION

Instructions for Use



WARNING: Always observe the safety instructions and applicable regulations.



WARNING: To reduce the risk of serious personal injury, turn tool off and disconnect tool from power source before making any adjustments or removing/installing attachments or accessories. Be sure the trigger switch is in the OFF position. An accidental start-up can cause injury.



WARNING:

- Always observe the safety instructions and applicable regulations.
- Be aware of the location of pipework and wiring.
- Apply only a gentle pressure to the tool (approx. 5 kg). Excessive force does not speed up drilling but decreases tool performance and may shorten tool life.
- Do not drill or drive too deep to prevent damage to the dust cover.
- Always hold the tool firmly with both hands and ensure a secure stance (Fig. I). Always operate the tool with the side handle properly mounted.

Proper Hand Position (Fig. I)



WARNING: To reduce the risk of serious personal injury, ALWAYS use proper hand position as shown.



WARNING: To reduce the risk of serious personal injury, ALWAYS hold securely in anticipation of a sudden reaction.

Proper hand position requires one hand on the side handle **8**, with the other hand on the main handle **2**.

Switching On and Off (Fig. A)

1. To run the tool, press the variable speed switch **1**. The pressure exerted on the variable speed switch determines the tool speed.
2. For continuous operation, press and hold down the variable speed switch.
3. To stop the tool, release the switch.

Hammerdrilling (Fig. A)

Drilling with a Solid Bit

1. Hold down the mode selector button **5** then set the mode selector switch **4** to the hammerdrilling position.
2. Insert the appropriate drill bit.

NOTE: For best results use high quality carbide-tipped bits.

3. Adjust the side handle **8** as required.
4. If necessary, set the drilling depth.
5. Mark the spot where the hole is to be drilled.
6. Place the drill bit on the spot and switch on the tool.
7. Always switch off the tool when work is finished and before unplugging.

Drilling with a Core Bit

1. Hold down the mode selector button **5** then set the mode selector switch **4** to the hammerdrilling position.
2. Adjust the side handle **8** as required.
3. Insert the appropriate core bit.
4. Assemble the centerdrill into the core bit.
5. Place the centerdrill on the spot and press the variable speed switch **1**. Drill until the core penetrates into the concrete approx. 1 cm.
6. Stop drilling and remove the centerdrill. Place the core bit back into the hole and continue drilling.
7. When drilling through a structure thicker than the depth of the core bit, break away the round cylinder of concrete or core inside the bit at regular intervals. To avoid unwanted breaking away of concrete around the hole, first drill a hole the diameter of the center drill completely through the structure. Then drill the cored hole halfway from each side.
8. Always switch off the tool when work is finished and before unplugging.

Rotary Drilling (Fig. A)

1. Hold down the mode selector button **5** then set the mode selector switch **4** to the "rotary drilling" position.
2. Depending on your tool, follow either of the following instructions:
 - **D25032, D25033, D25133, D25143:** Fit the chuck adapter/chuck assembly.
 - **D25134, D25144:** Replace the SDS plus® tool holder with the keyless chuck.
3. Proceed as described for hammerdrilling.



WARNING: Never use standard chucks in the hammerdrilling mode.

Screwdriving (Fig. A)

1. Hold down the mode selector button **5** then set the mode selector switch **4** to the rotary drilling position.
2. Select the direction of rotation.
3. Depending on your tool, follow either of the following instructions:
 - **D25032, D25033, D25133, D25143:** Insert the special SDS plus® screwdriving adaptor for use with hexagonal screwdriver bits.
 - **D25134, D25144:** Replace the SDS plus® tool holder with the keyless chuck.
4. Insert the appropriate screwdriver bit. When driving slotted head screws always use bits with a finder sleeve.

- Gently press the variable speed switch **1** to prevent damage to the screw head. In reverse (LH) rotation the tool speed is automatically reduced for easy screw removal.
- When the screw is flush with the workpiece, release the variable speed switch to prevent the screw head from penetrating into the workpiece.

Chipping and Chiselling (Fig. A)

D25033, D25133, D25134, D25143, D25144

- Hold down the mode selector button **5** then set the mode selector switch **4** to the "hammering only" position.
- Insert the appropriate chisel and rotate it by hand to lock it into position.
- Adjust the side handle **8** as required.
- Switch on the tool and start working.
- Always switch off the tool when work is finished and before unplugging.



WARNING:

- Do not use this tool to mix or pump easily combustible or explosive fluids (benzene, alcohol, etc.).
- Do not mix or stir in flammable liquids labelled accordingly.

MAINTENANCE

Your DeWALT power tool has been designed to operate over a long period of time with a minimum of maintenance. Continuous satisfactory operation depends upon proper tool care and regular cleaning.



WARNING: To reduce the risk of serious personal injury, turn tool off and disconnect tool from power source before making any adjustments or removing/installing attachments or accessories. Be sure the trigger switch is in the OFF position. An accidental start-up can cause injury.

- This machine is not user-serviceable. Take the tool to an authorised DeWALT repair agent after approximately 40 hours of use. If problems occur before this time contact an authorised DeWALT repair agent.
- The tool will automatically switch off when the carbon brushes are worn.

Motor Brushes

DeWALT uses an advanced brush system which automatically stops the drill when the brushes wear out. This prevents serious damage to the motor. New brush assemblies are available at authorised DeWALT service centers. Always use identical replacement parts.

Lubrication

Your power tool requires no additional lubrication.

Accessories and attachments used must be regularly lubricated around the SDS plus® fitment.

Cleaning



WARNING: Electrical shock and mechanical hazard.

Disconnect the electrical appliance from the power source before cleaning.



WARNING: To ensure safe and efficient operation, always keep the electrical appliance and the ventilation slots clean.



WARNING: Never use solvents or other harsh chemicals for cleaning the non-metallic parts of the tool. These chemicals may weaken the materials used in these parts. Use a cloth dampened only with water and mild soap. Never let any liquid get inside the tool; never immerse any part of the tool into a liquid.

Ventilation slots can be cleaned using a dry, soft non-metallic brush and/or a suitable vacuum cleaner. Do not use water or any cleaning solutions. Wear approved eye protection and an approved dust mask.

Optional Accessories



WARNING: Since accessories, other than those offered by DeWALT, have not been tested with this product, use of such accessories with this tool could be hazardous. To reduce the risk of injury, only DeWALT recommended accessories should be used with this product.

Various types of SDS plus® drill bits and chisels are available as an option.

Consult your dealer for further information on the appropriate accessories.

Protecting the Environment



Separate collection. Products and batteries marked with this symbol must not be disposed of with normal household waste.



Products and batteries contain materials that can be recovered or recycled reducing the demand for raw materials. Please recycle electrical products and batteries according to local provisions. Further information is available at www.2helpU.com.

SDS plus® and SDS max® are registered trademarks of Robert Bosch GmbH.

Belgique et Luxembourg België en Luxemburg	DeWALT - Belgium BVBA Egide Walschaertsstraat 16 2800 Mechelen	Tel: NL 32 15 47 37 63 Tel: FR 32 15 47 37 64 Fax: 32 15 47 37 99	www.dewalt.be enduserv.BE@SBDinc.com
Danmark	DeWALT (Stanley Black&Decker AS) Roskildevej 22 2620 Albertslund	Tel: 70 20 15 10 Fax: 70 22 49 10	www.dewalt.dk kundeservice.dk@sbdinc.com
Deutschland	DeWALT Richard-Klinger-Str. 11 65510 Idstein	Tel: 06126-21-0 Fax: 06126-21-2770	www.dewalt.de infodwge@sbdinc.com
Ελλάς	DeWALT (ΕΜΔΑ) Α.Ε. ΕΔΡΑ-ΓΡΑΦΕΙΑ : Στραβίωνος 7 & Α. Βουλιαγμένης, Γλυφάδα 166 74, Αθήνα SERVICE : Ημέρος Τόπος 2 (Χάιν Αδάμ) – 193 00 Ασπίστηπος	Τηλ: 00302108981616 Φαξ: 00302108983570	www.dewalt.gr Greece.Service@sbdinc.com
España	DeWALT Ibérica, S.C.A. Parc de Negocios "Mas Blau" Edificio Muntadas, c/Bergadà, 1, Of. A6 08820 El Prat de Llobregat (Barcelona)	Tel: 934 797 400 Fax: 934 797 419	www.dewalt.es respuesta.postventa@sbdinc.com
France	DeWALT (Stanley Black & Decker France SAS) 62 Chemin de la Bruyère 69570 Dardilly, France	Tel: 04 72 20 39 20 Fax: 04 72 20 39 00	www.dewalt.fr scufr@sbdinc.com
Schweiz Suisse Svizzera	DeWALT In der Luberzen 42 8902 Urdorf	Tel: 044 - 755 60 70 Fax: 044 - 730 70 67	www.dewalt.ch service@rofoag.ch
Ireland	DeWALT Building 4500, Kinsale Road Cork Airport Business Park Cork, Ireland	Tel: 00353-2781800 Fax: 01278 1811	www.dewalt.ie Sales.ireland@sbdinc.com
Italia	DeWALT via Energypark 6 20871 Vimercate (MB), IT	Tel: 800-014353 39 039-9590200 Fax: 39 039-9590311	www.dewalt.it
Nederlands	DeWALT Netherlands BVPostbus 83, 6120 AB BORN	Tel: 31 164 283 063 Fax: 31 164 283 200	www.dewalt.nl
Norge	DeWALT Postboks 4613 0405 Oslo, Norge	Tel: 45 25 13 00 Fax: 45 25 08 00	www.dewalt.no kundeservice.no@sbdinc.com
Österreich	DeWALT Werkzeug Vertriebsges m.b.H Oberlaaerstrasse 248, A-1230 Wien	Tel: 01 - 66116 - 0 Fax: 01 - 66116 - 614	www.dewalt.at service.austria@sbdinc.com
Portugal	DeWALT Ed. D Dinis, Quina da Fonte Rua dos Malhoes 2 2A 2º Esq. Oeiras e S. Juliao da Barra, paço de Arcos e Caxias 2770 071 Paço de Arcos	Tel: +351 214667500 Fax: +351214667580	www.dewalt.pt resposta.posvenda@sbdinc.com
Suomi	DeWALT PL47 00521 Helsinki, Suomi	Puh: 010 400 4333 Faksi: 0800 411 340	www.dewalt.fi asiakaspalvelu.fi@sbdinc.com
Sverige	DeWALT BOX 94 43122 Mölndal Sverige	Tel: 031 68 61 60 Fax: 031 68 60 08	www.dewalt.se kundservice.se@sbdinc.com
Türkiye	Sanayi ve Ticaret Bakanlığı tebliğince kullanım ömrü 7 yıldır. Stanley Black & Decker Turkey Alet Üretim San. Tic. Ltd.Şti. AND Kozyatığı – İçerenköy Mah. Umur Sok. AND Ofis No: 10-12 / 82-83-84 Ataşehir/İstanbul, Türkiye	Tel: +90 216 665 2900 Faks: +90 216 665 2901	www.dewalt.com.tr support@dewalt.com.tr
United Kingdom	DeWALT, 270 Bath Road, Slough, Berks SL1 4DX	Tel: 01753-567055 Fax: 01753-572112	www.dewalt.co.uk emeaservice@sbdinc.com
Australia / New Zealand	DeWALT 810 Whitehorse Road Box Hill VIC 3128 Australia	Tel: Aust 1800 654 155 Tel: NZ 0800 339 258	www.dewalt.com.au www.dewalt.co.nz
Middle East Africa	DeWALT P.O. Box - 17164, Jebel Ali Free Zone (South), Dubai, UAE	Tel: 971 4 812 7400 Fax: 971 4 2822765	www.dewalt.ae support@dewalt.ae