

DEWALT®

www.DEWALT.com

D24000

Fig. A1

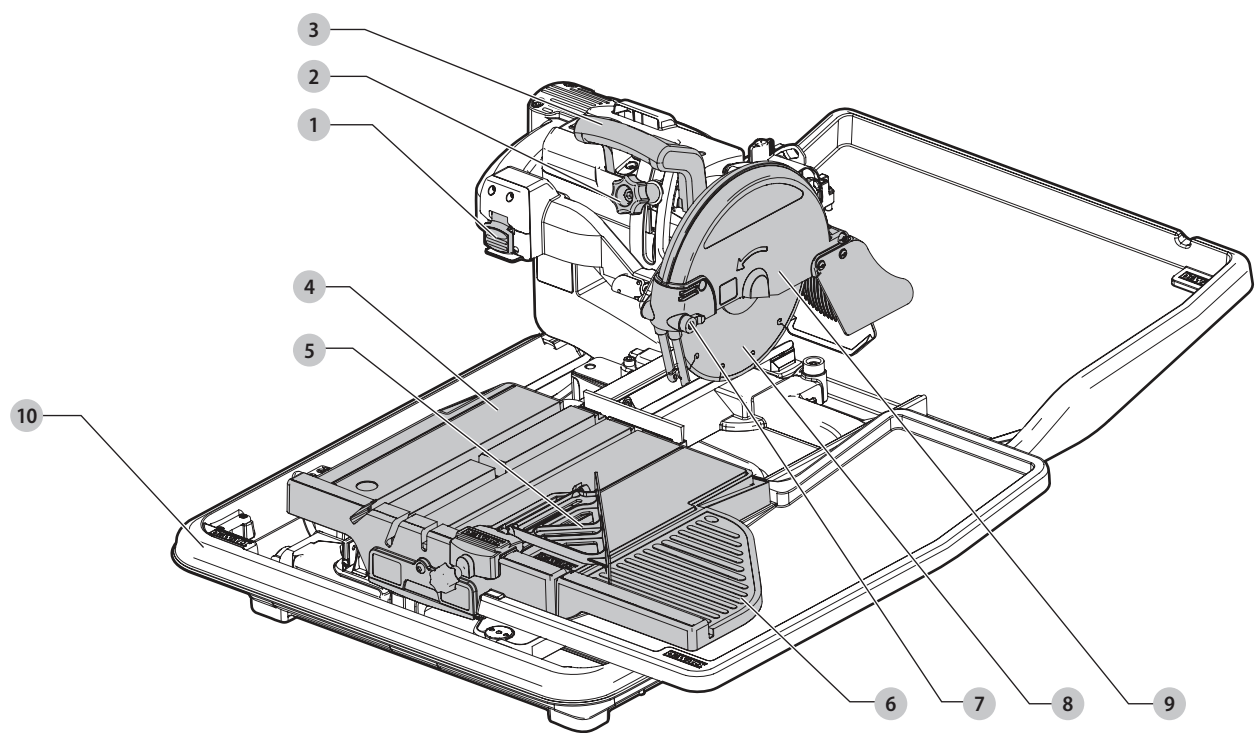

Fig. A2

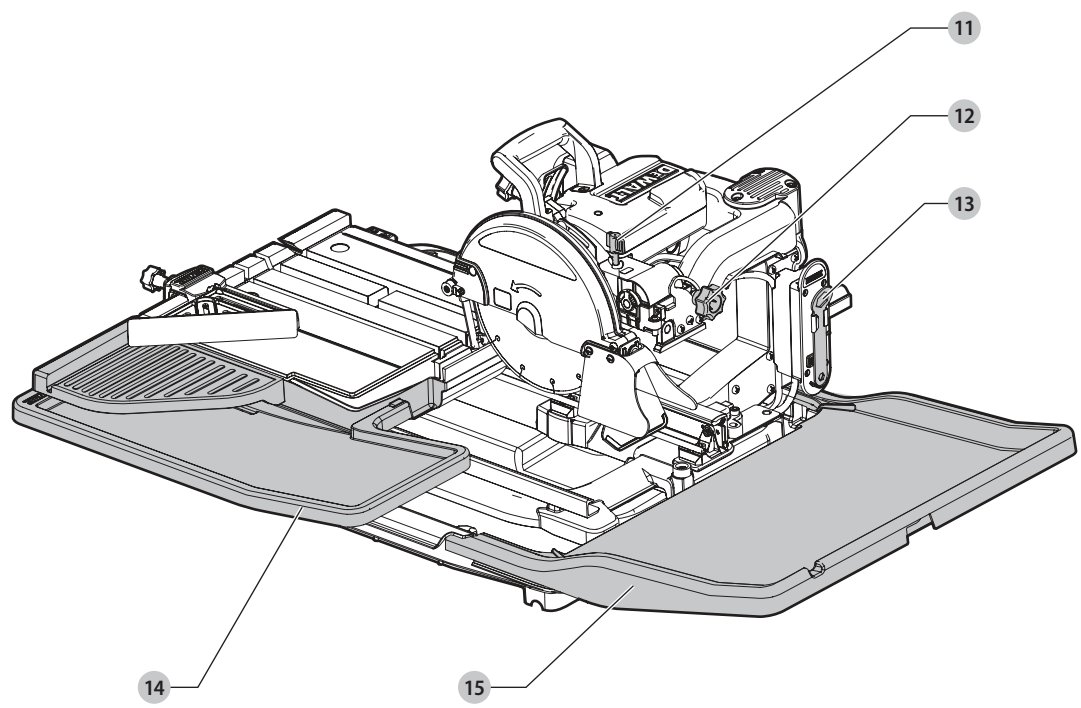

Fig. B1

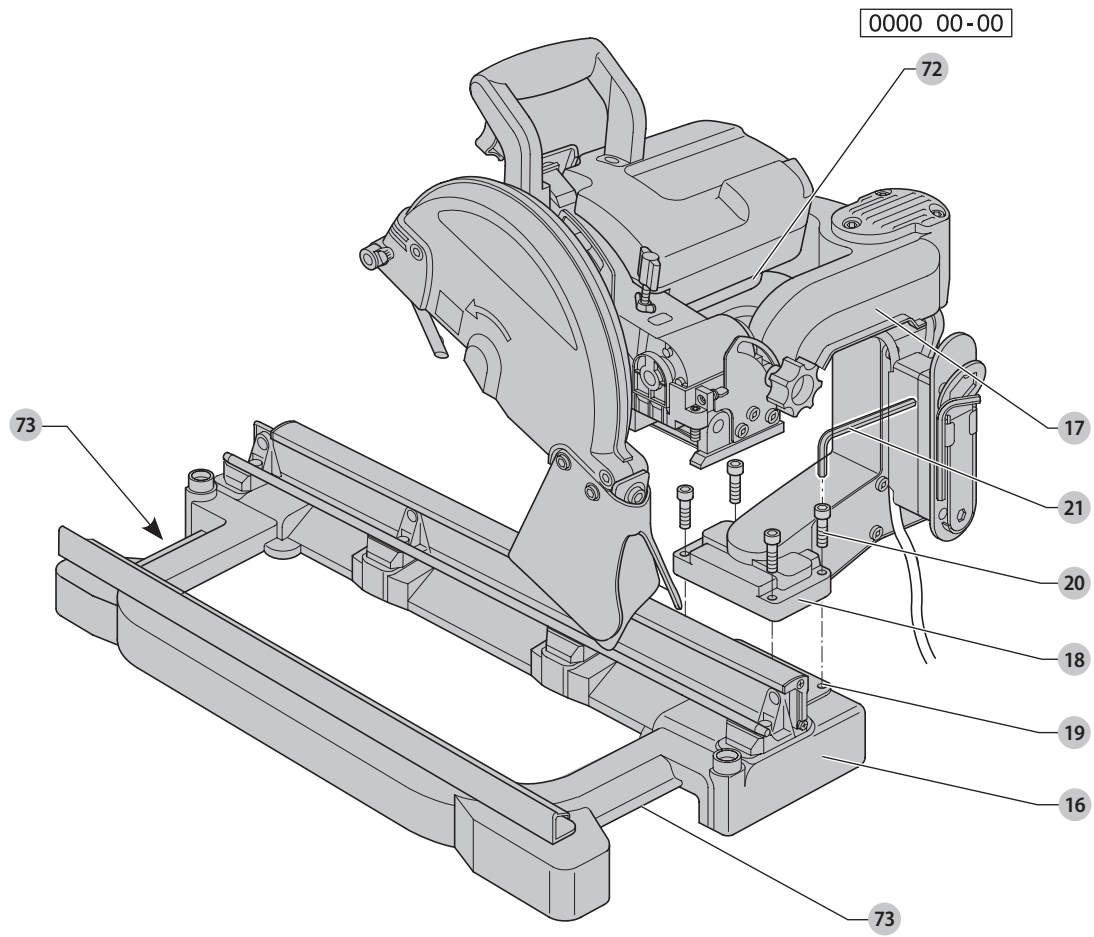

Fig. B2

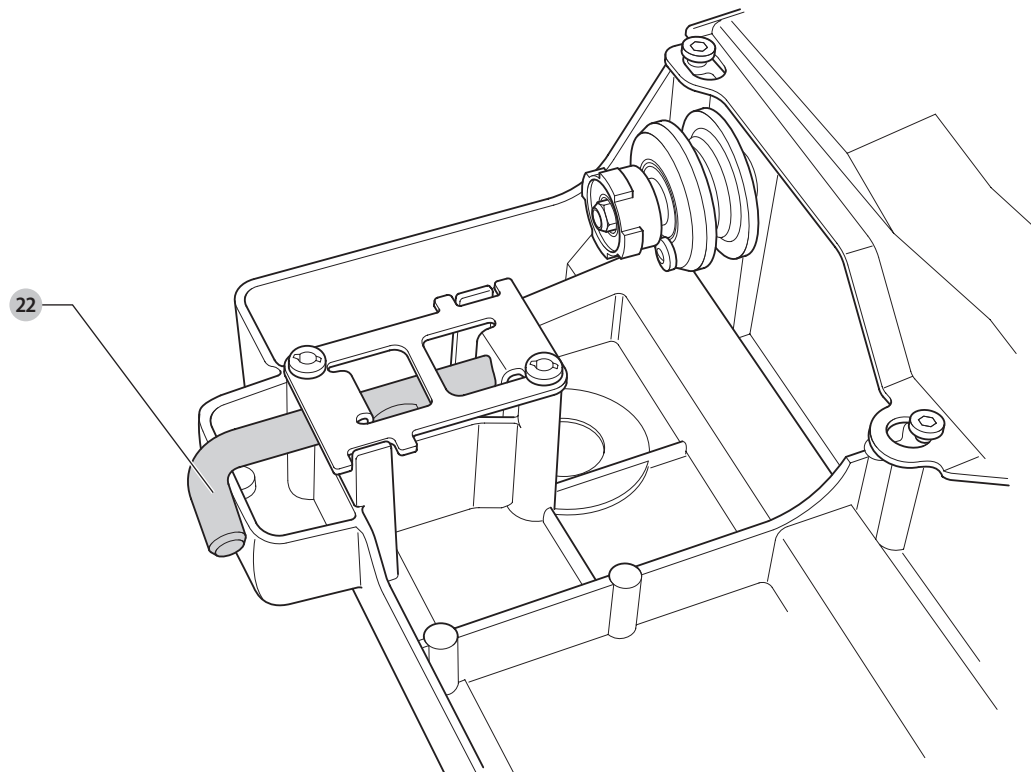

Fig. B3

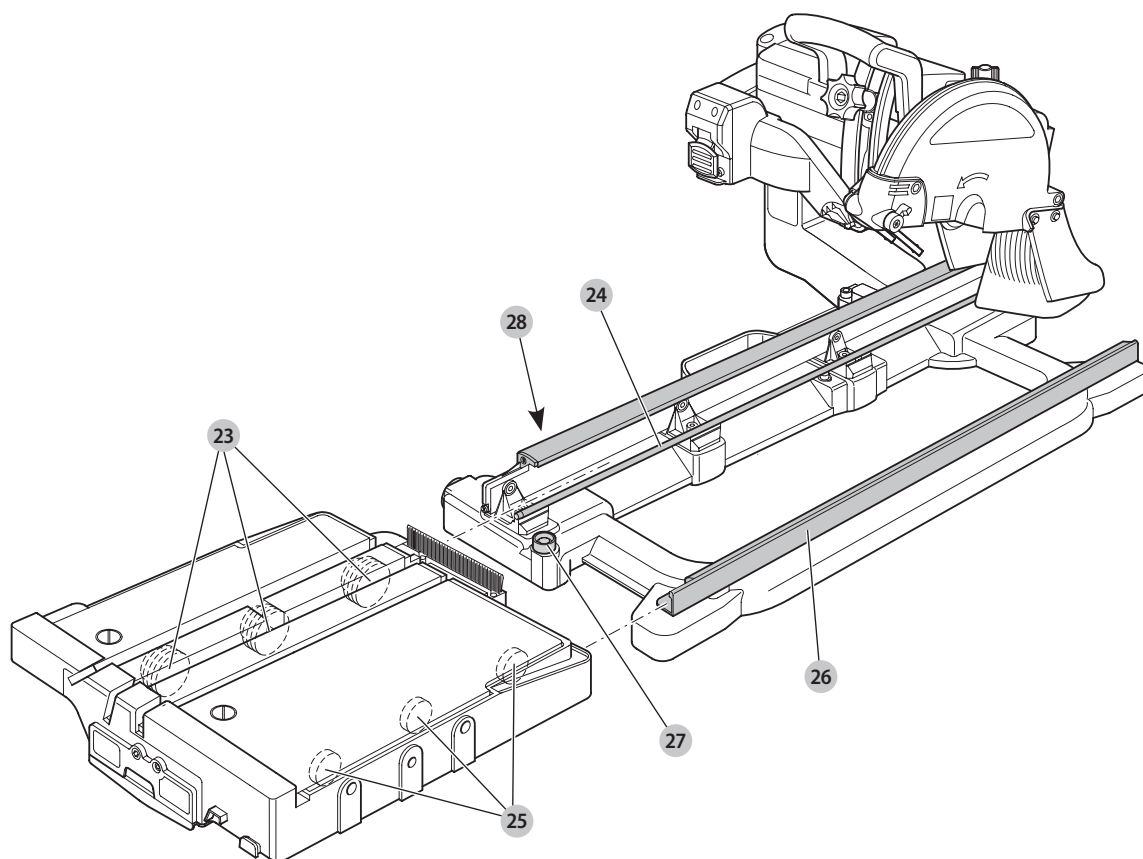

Fig. B4

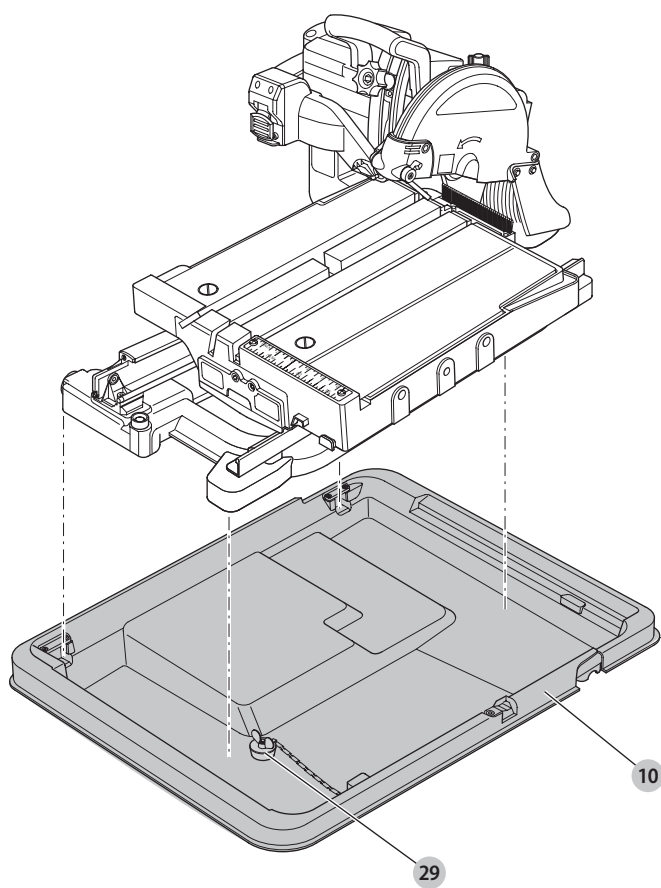

Fig. C

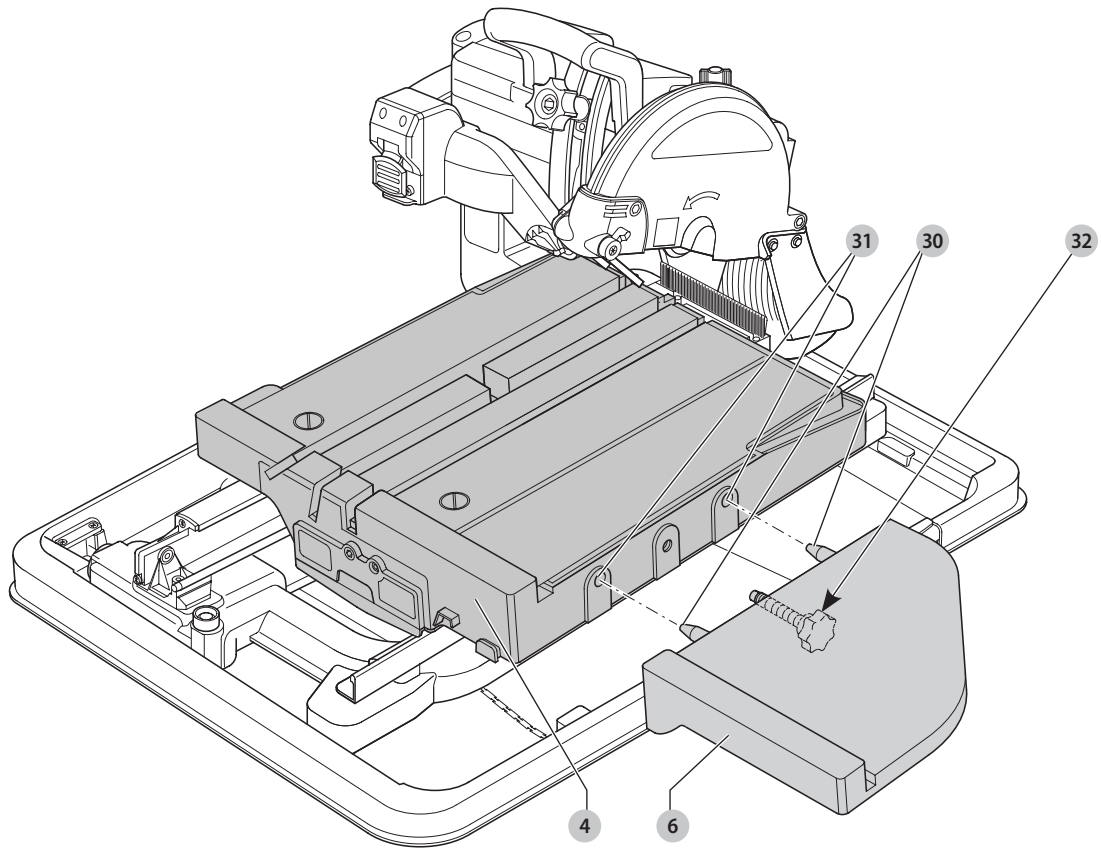

Fig. D1

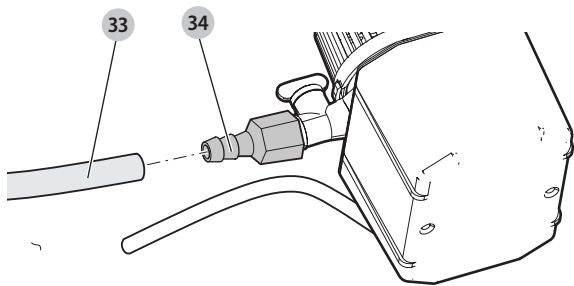

Fig. D2

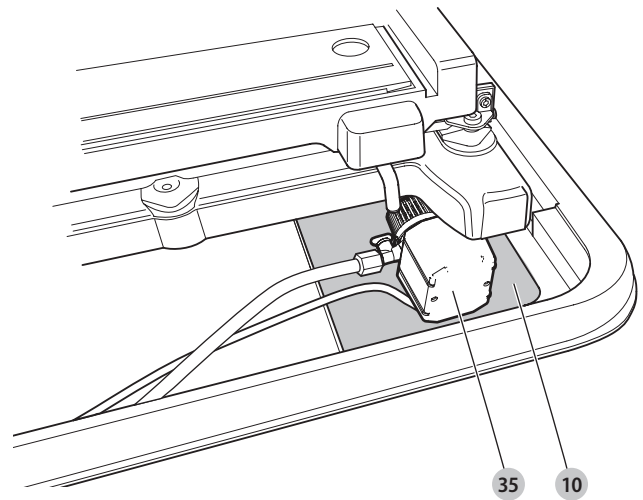

Fig. E1

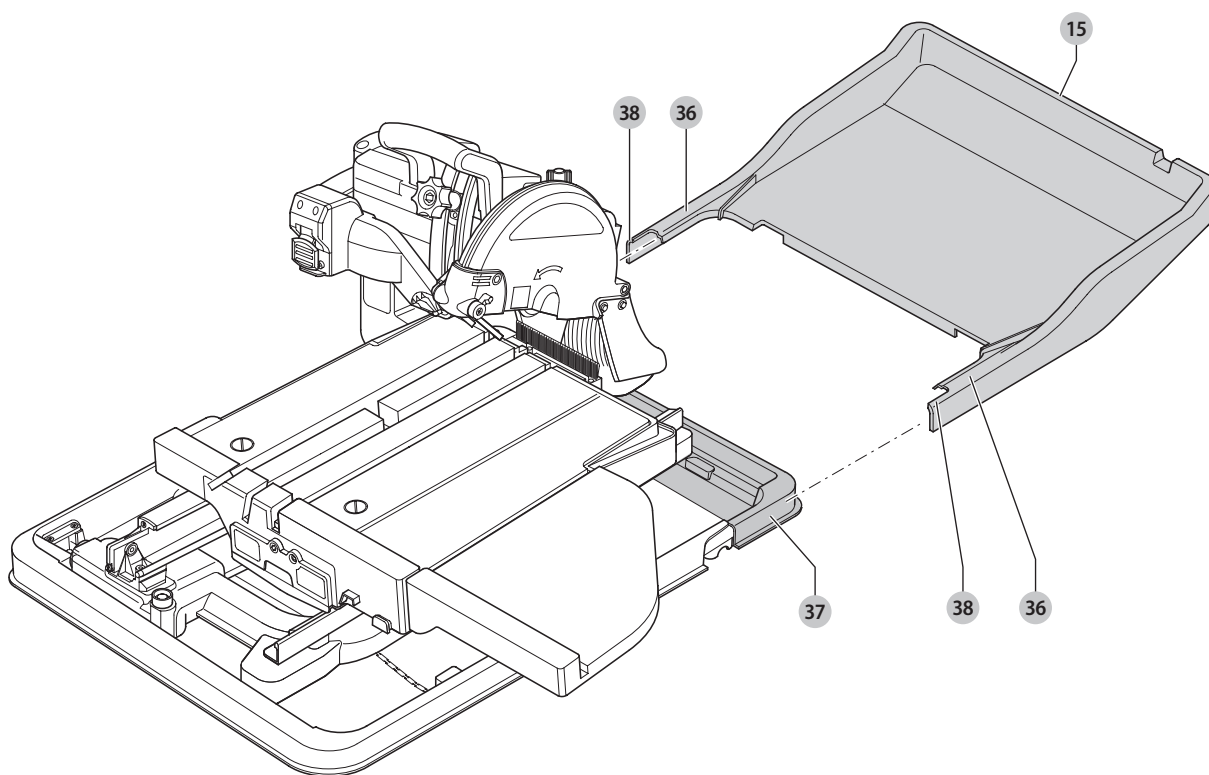

Fig. E2

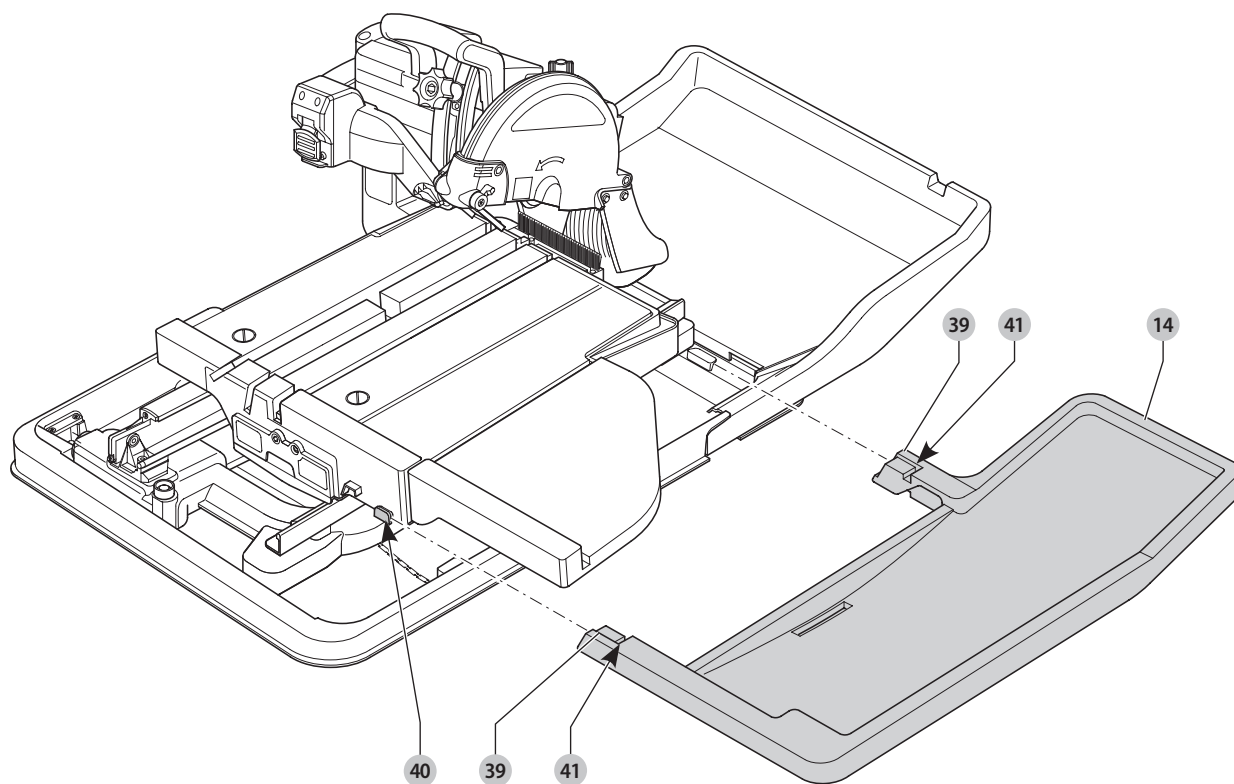

Fig. F1

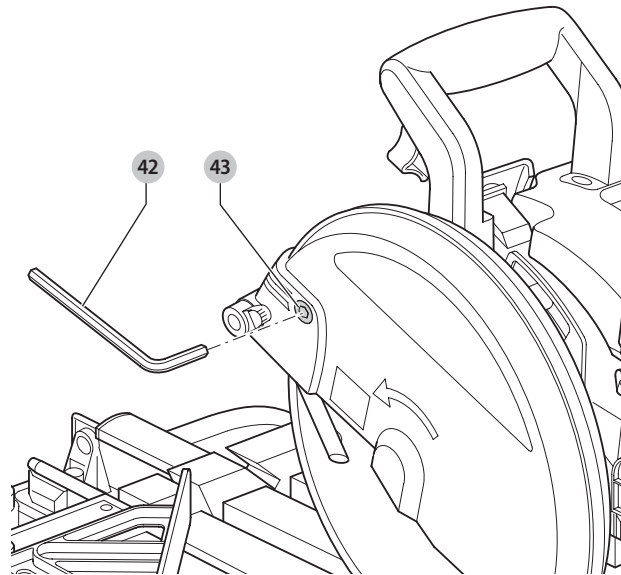

Fig. F2

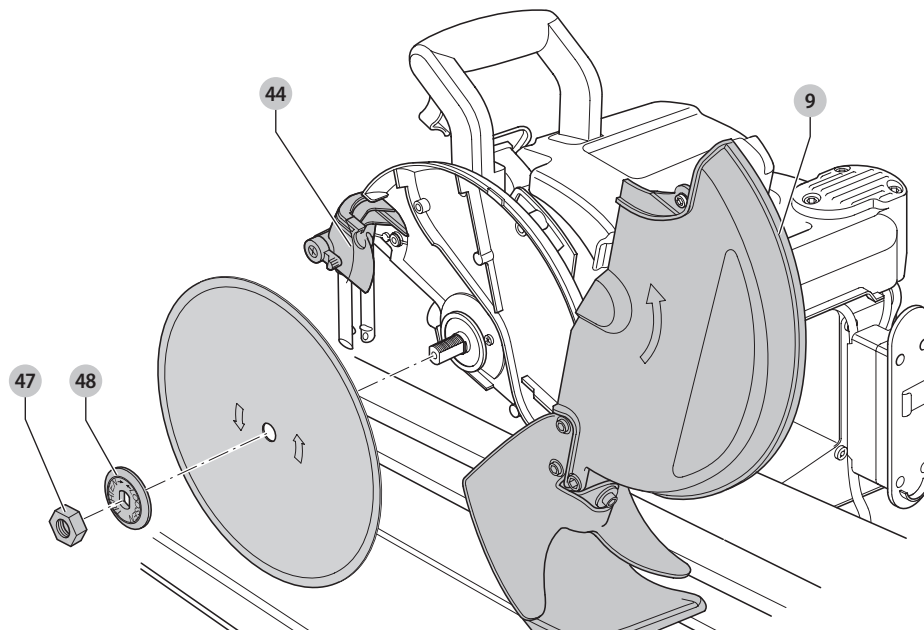

Fig. F3

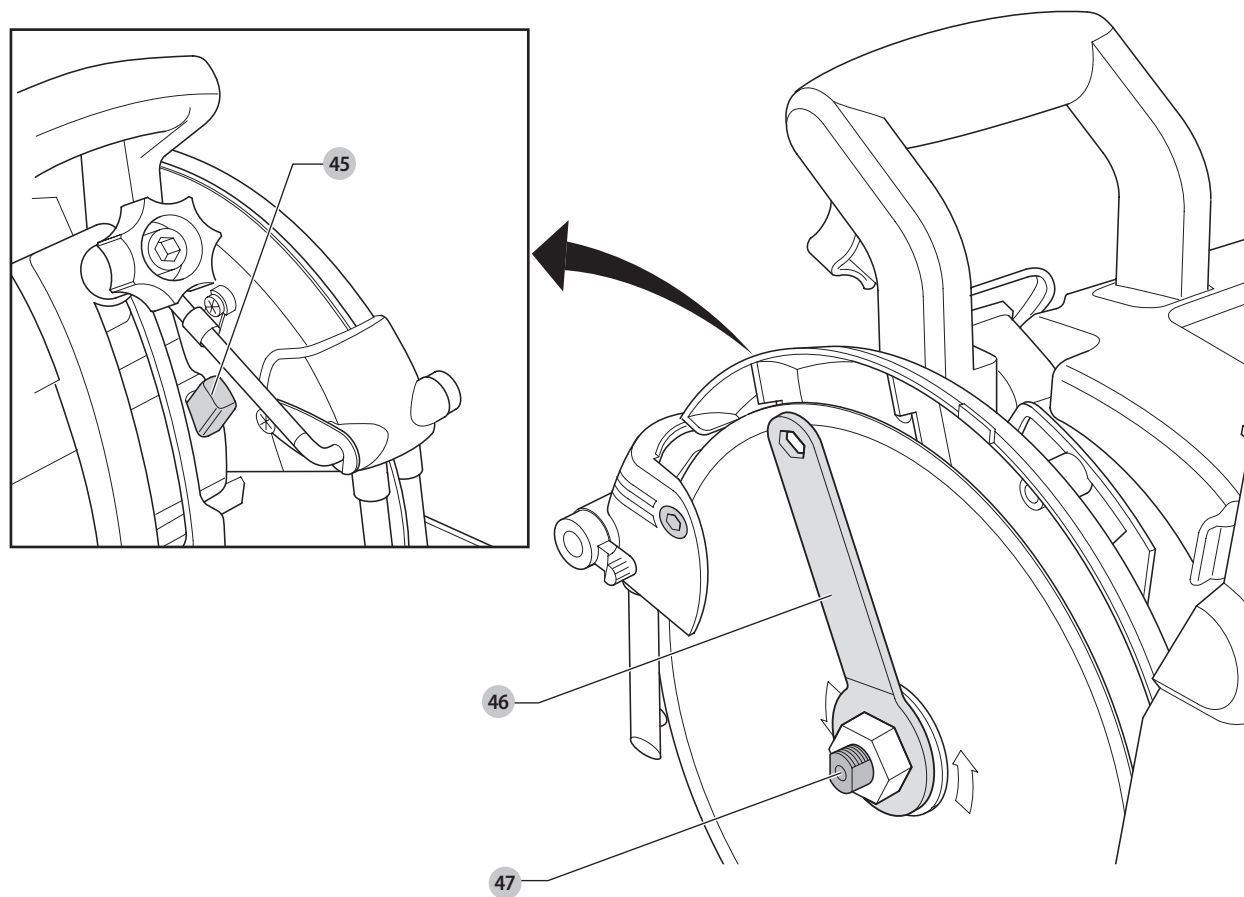

Fig. G

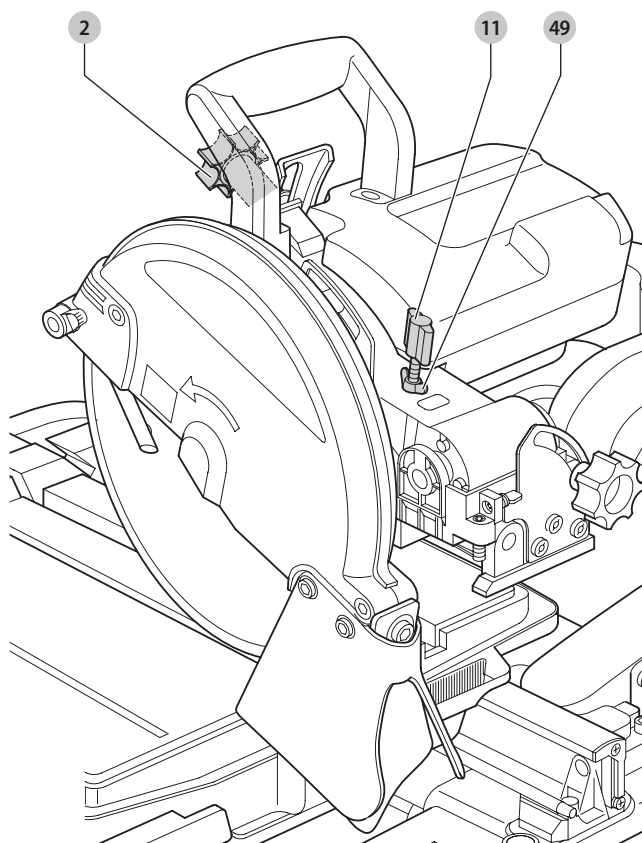

Fig. H1

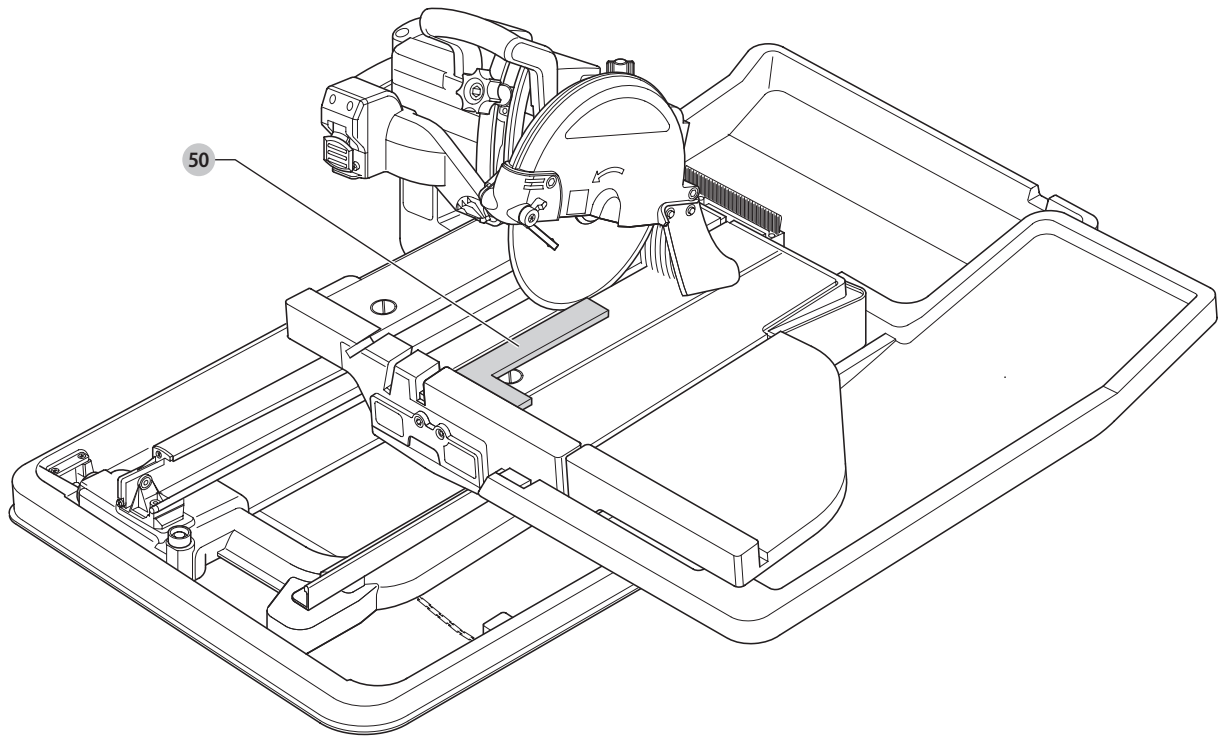

Fig. H2

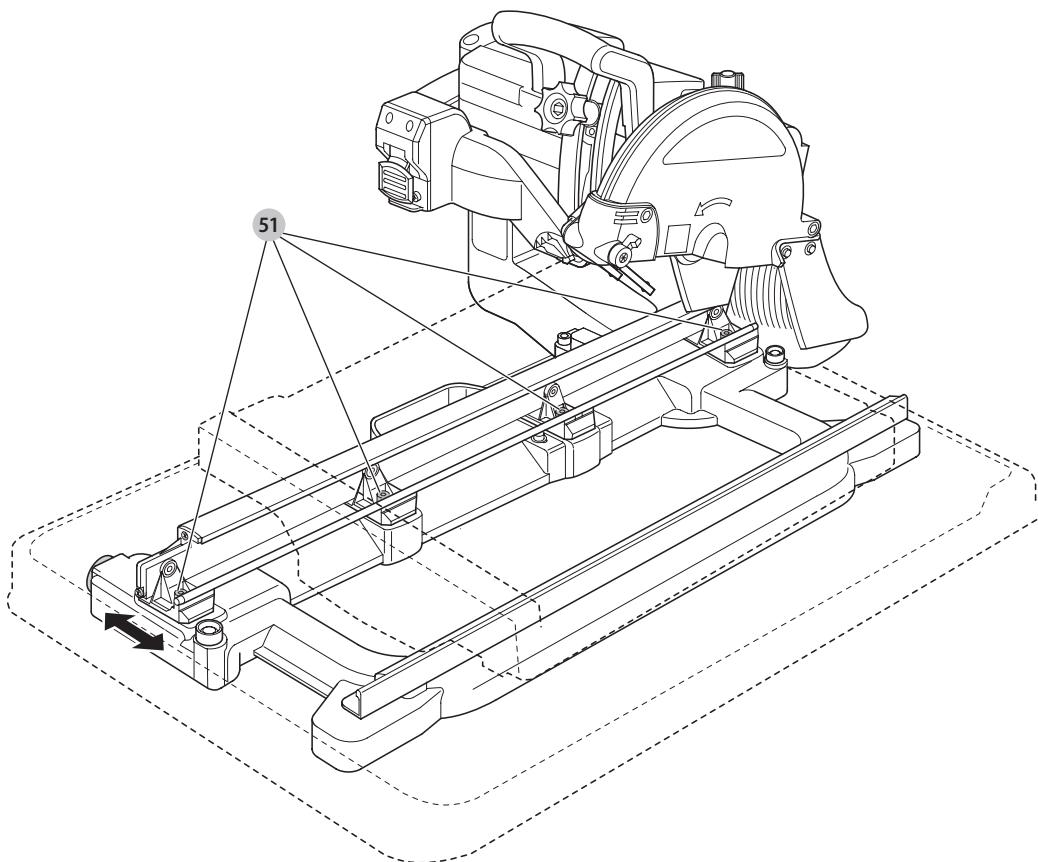

Fig.11

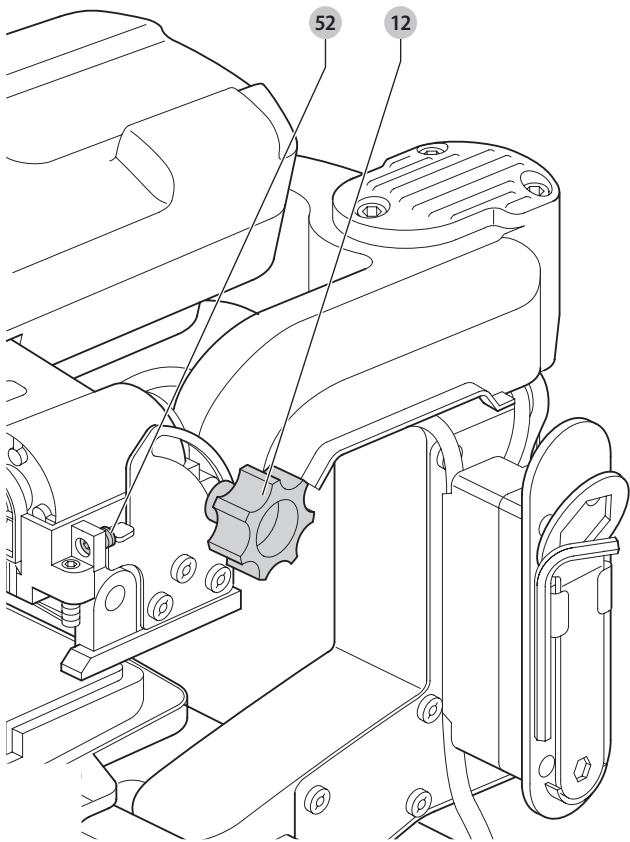

Fig.13

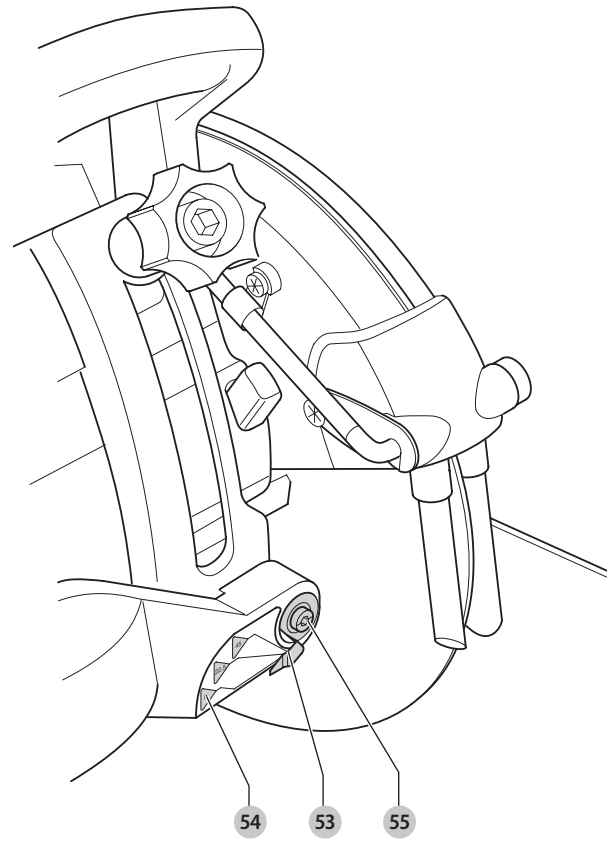

Fig.12

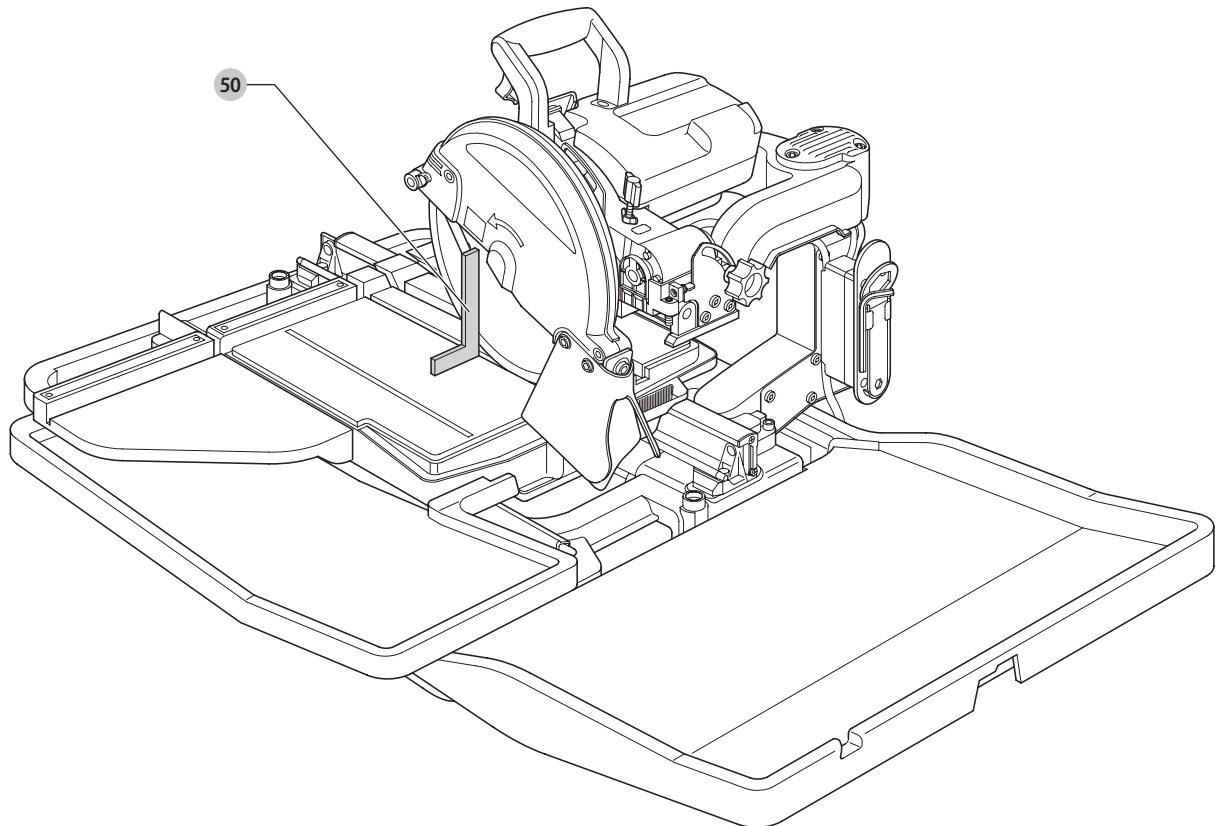

Fig. J

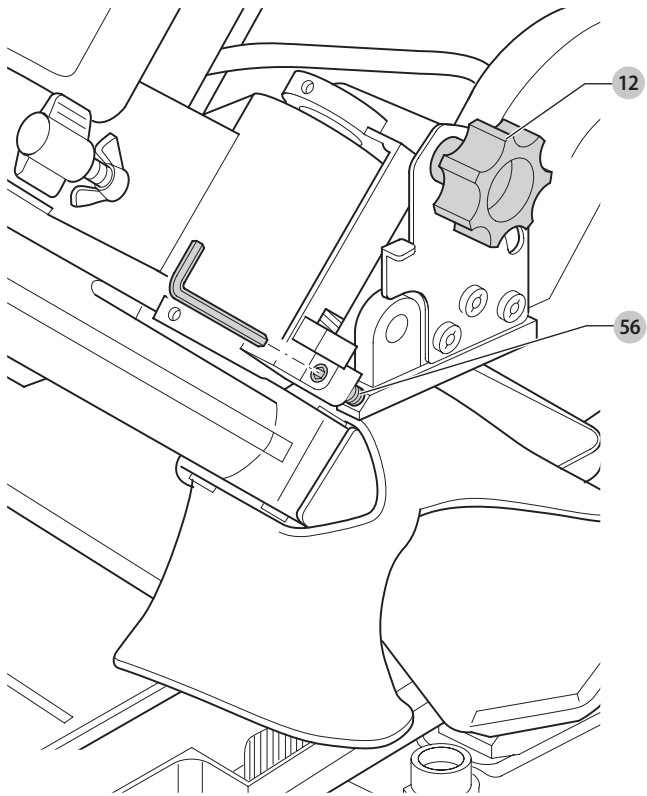

Fig. K

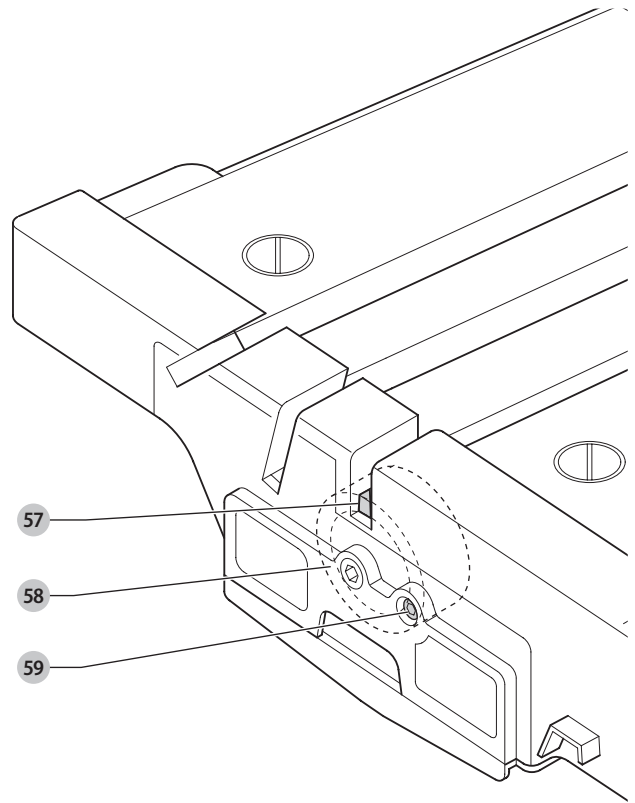

Fig. L

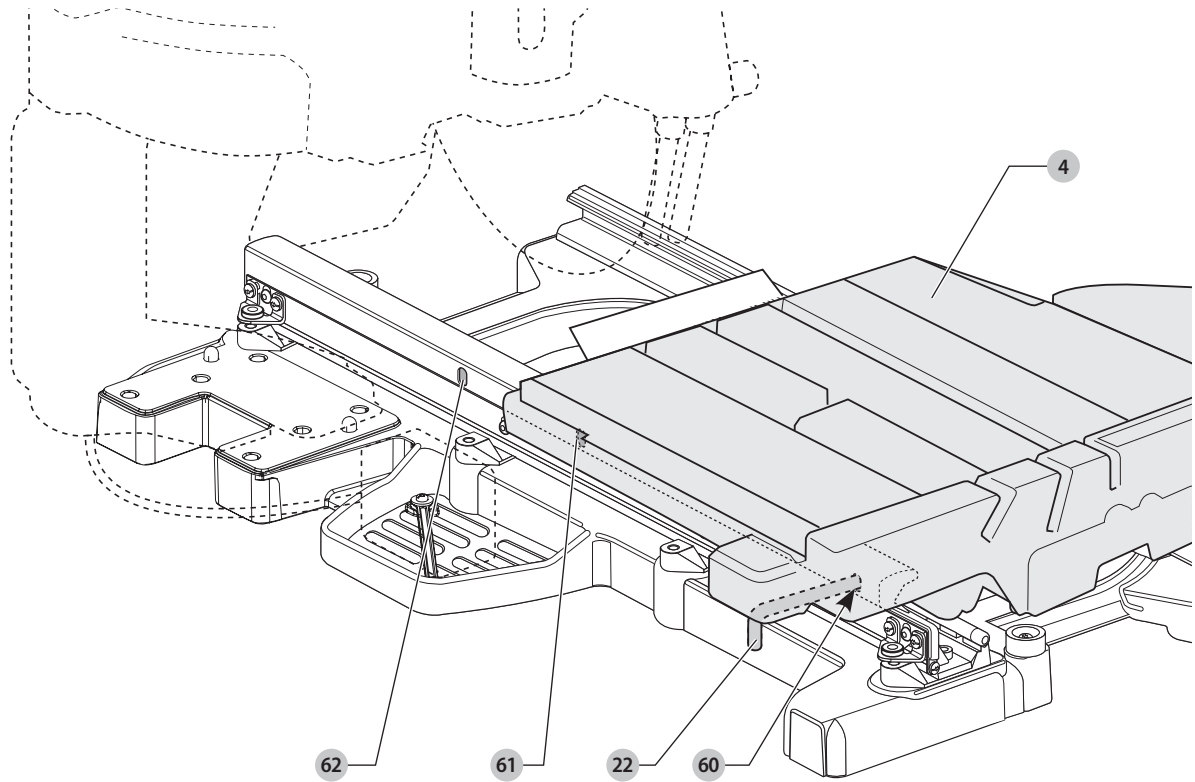

Fig. M

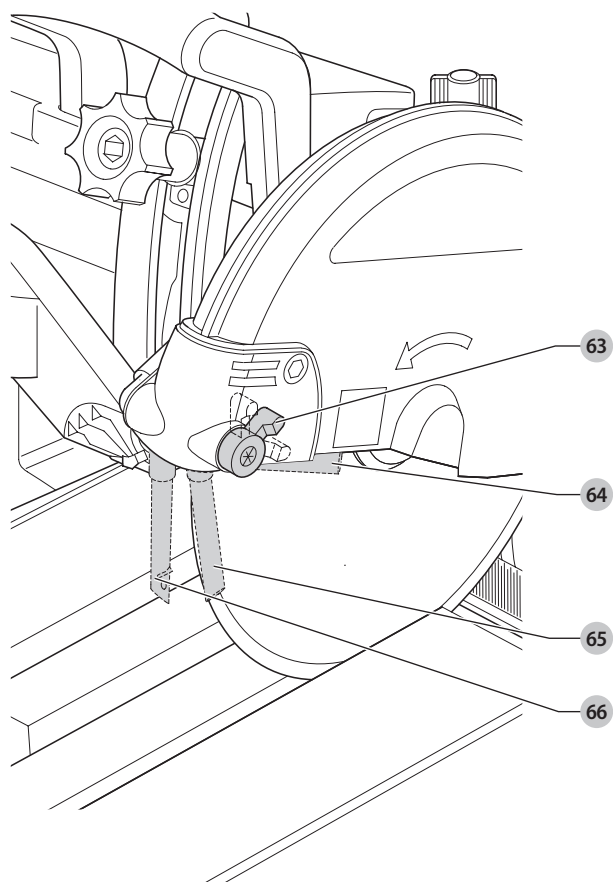

Fig. N

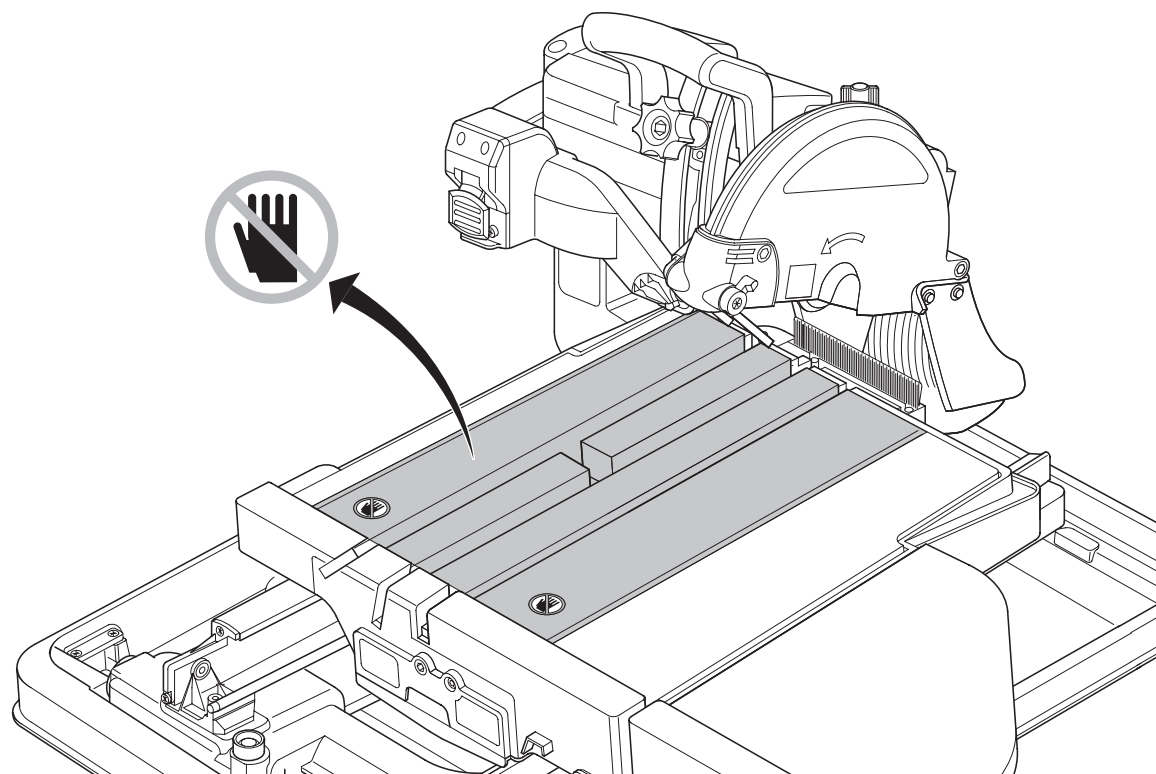

Fig. O

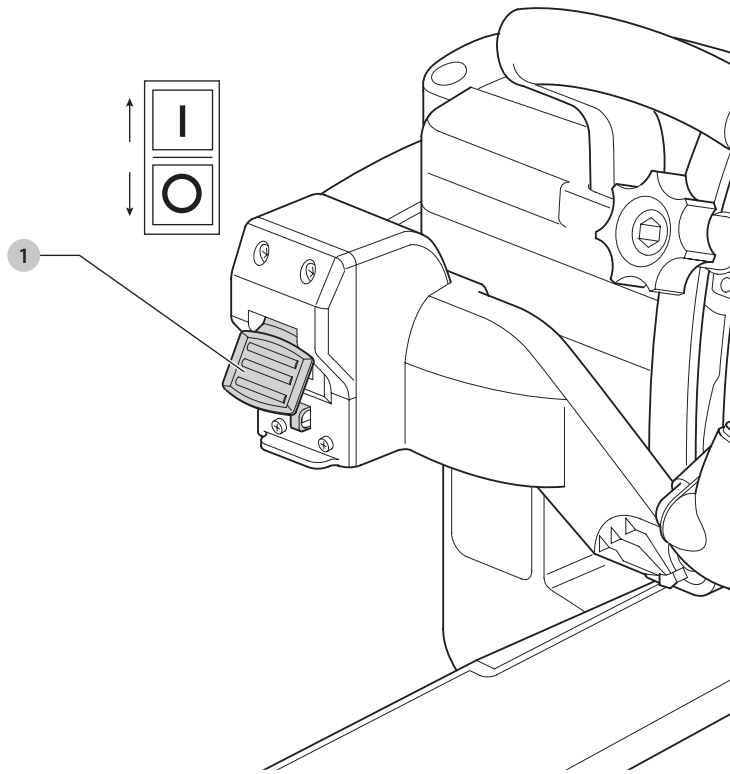

Fig. P

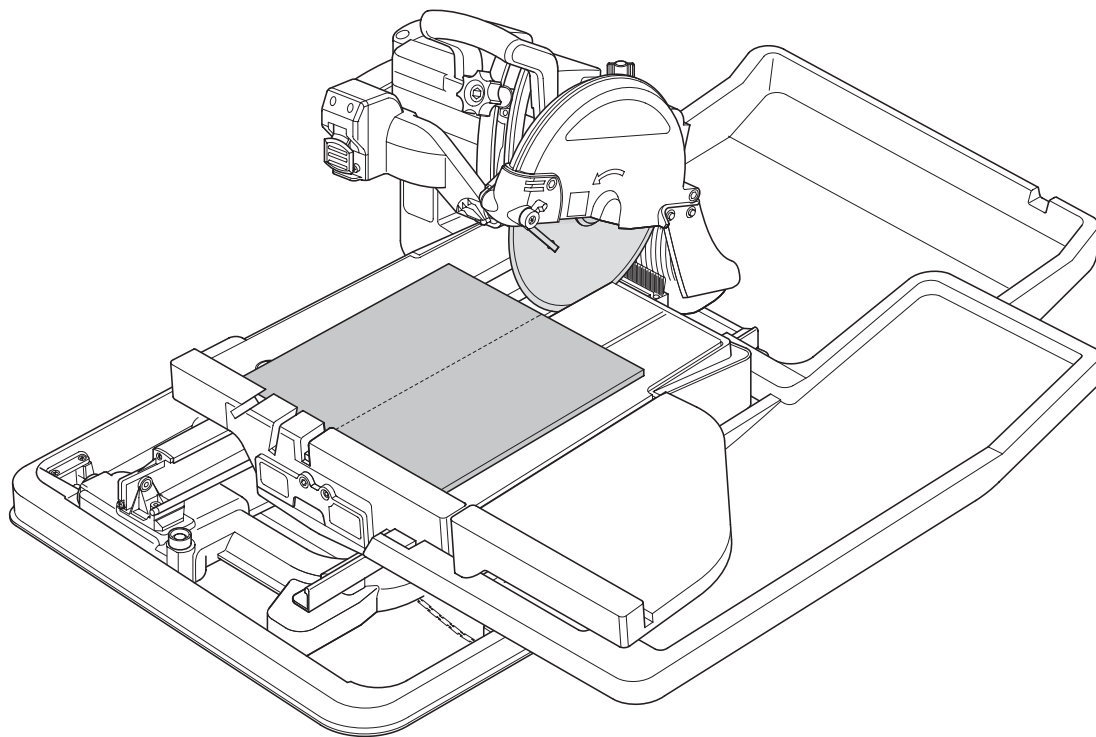

Fig. Q

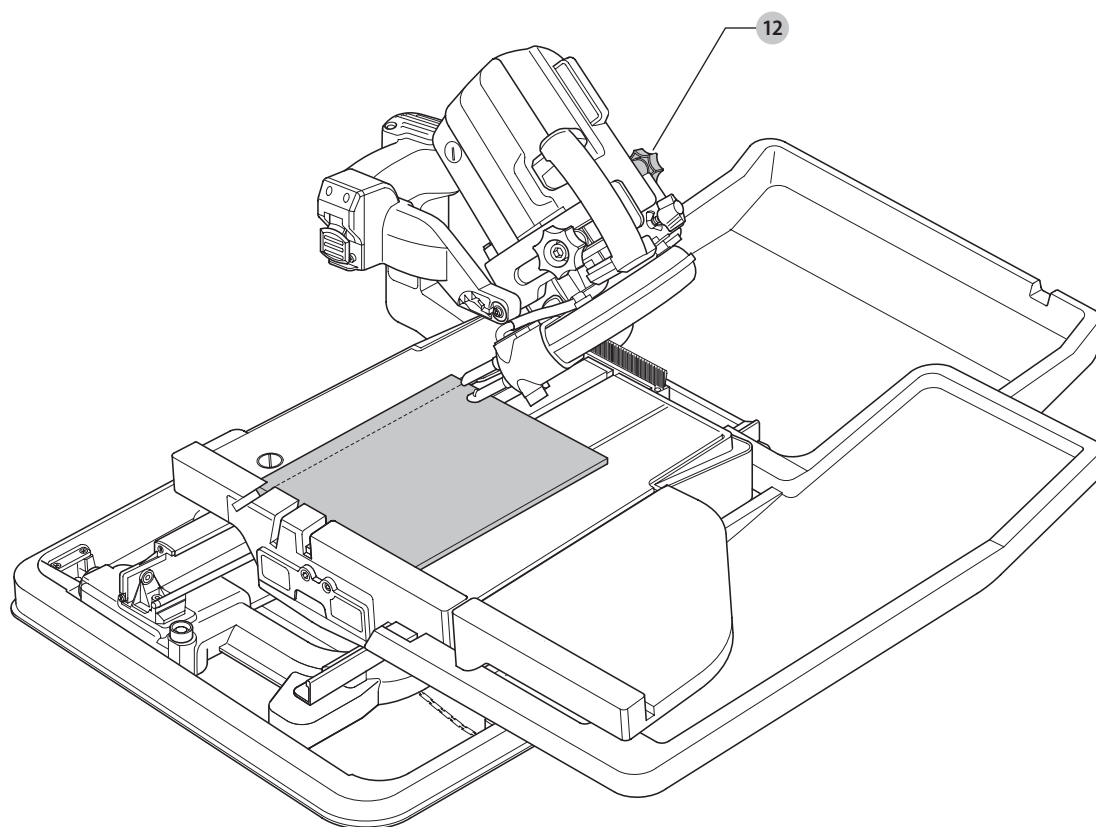

Fig. R1

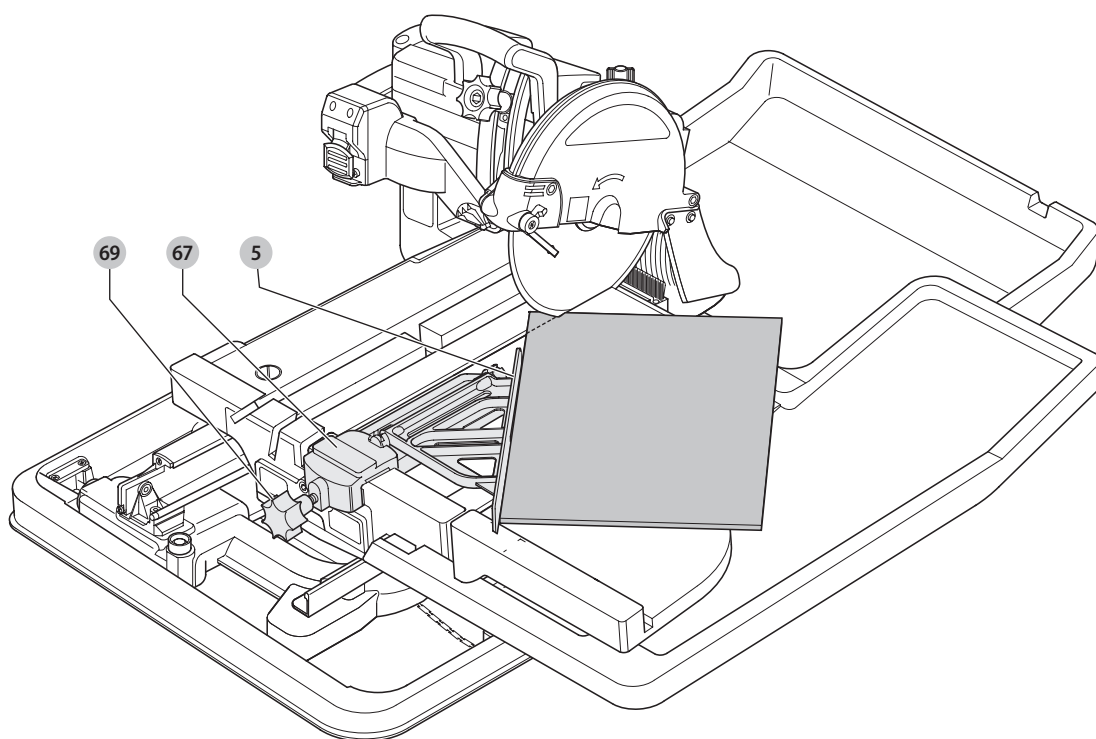

Fig. R2

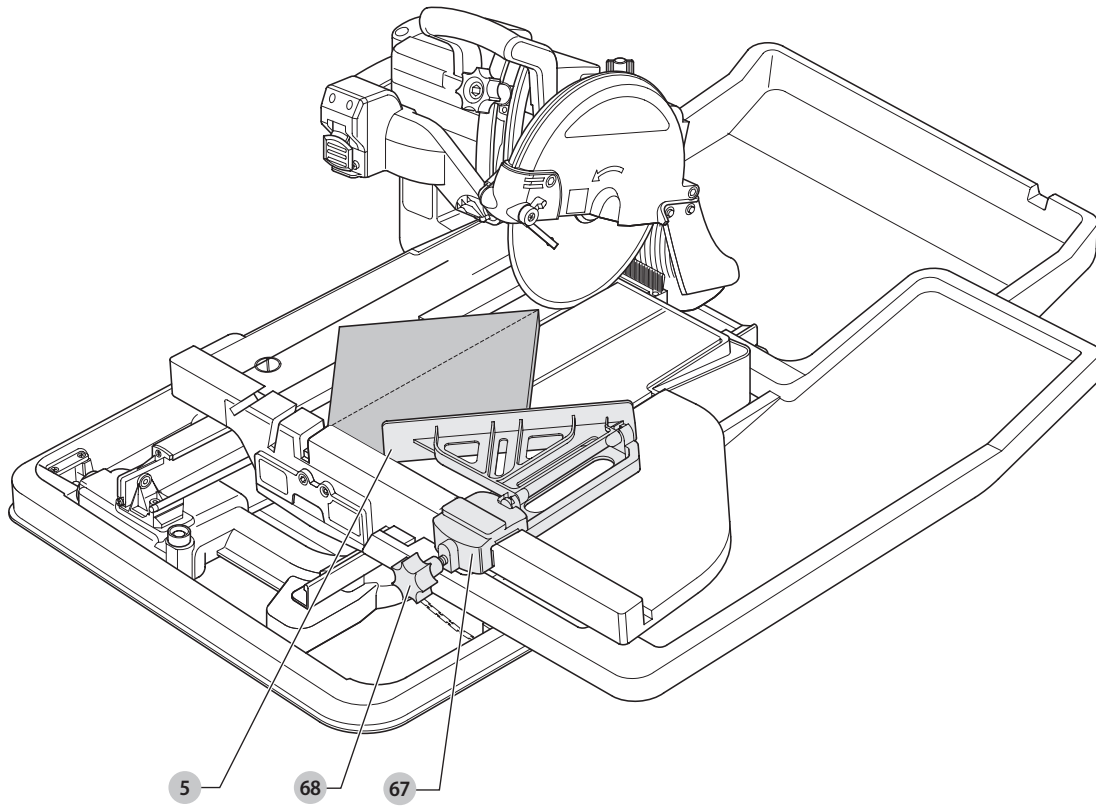

Fig. S

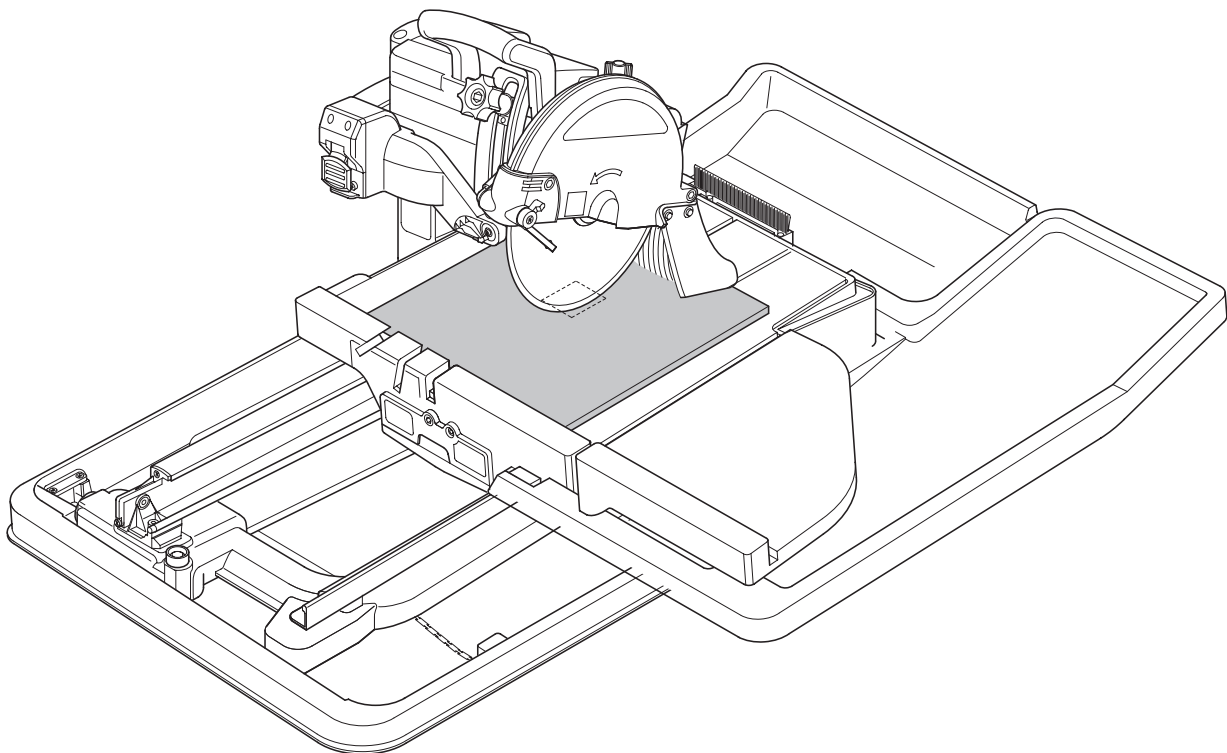

Fig. T

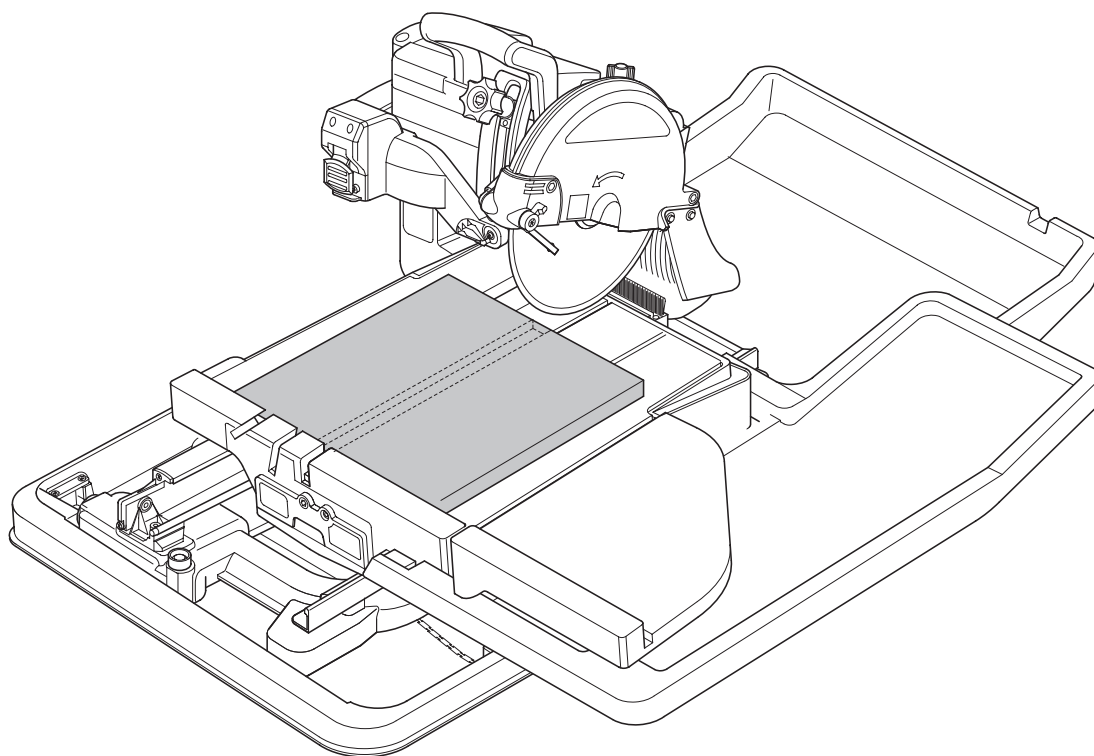

Fig. U

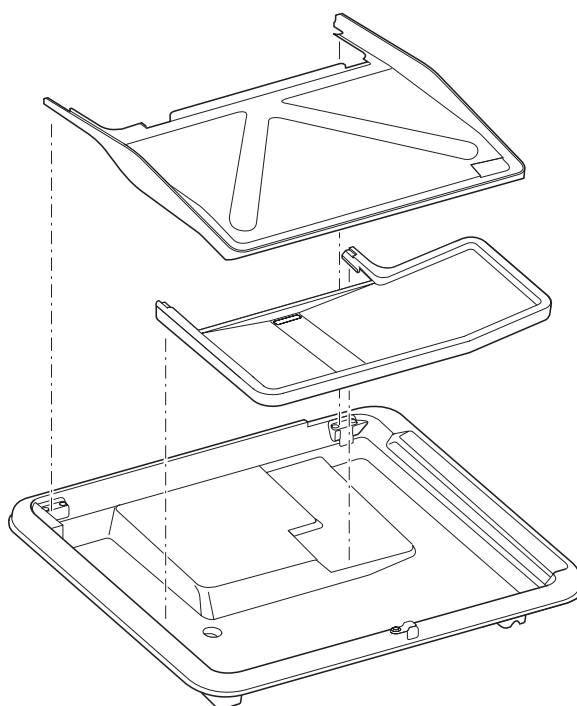

Fig.V

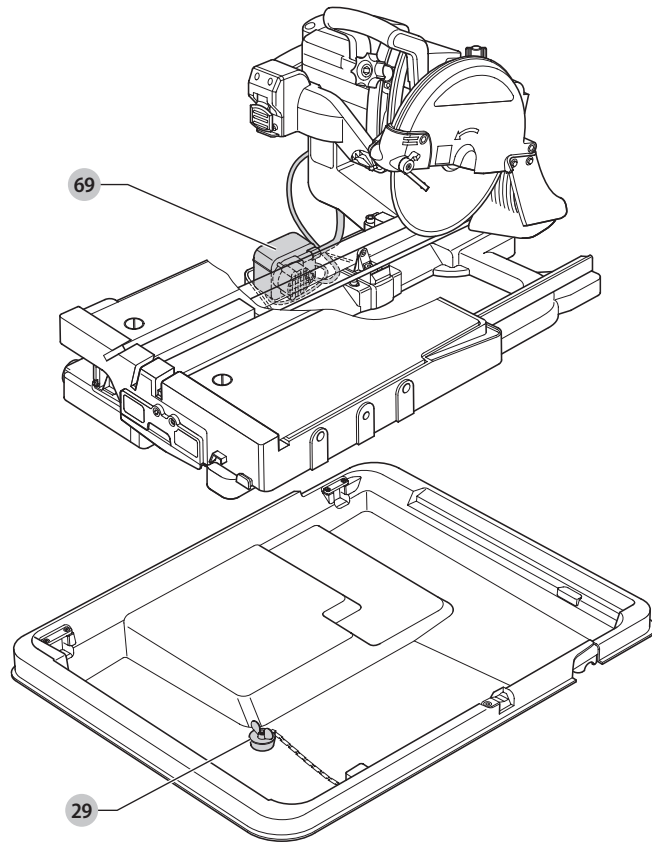
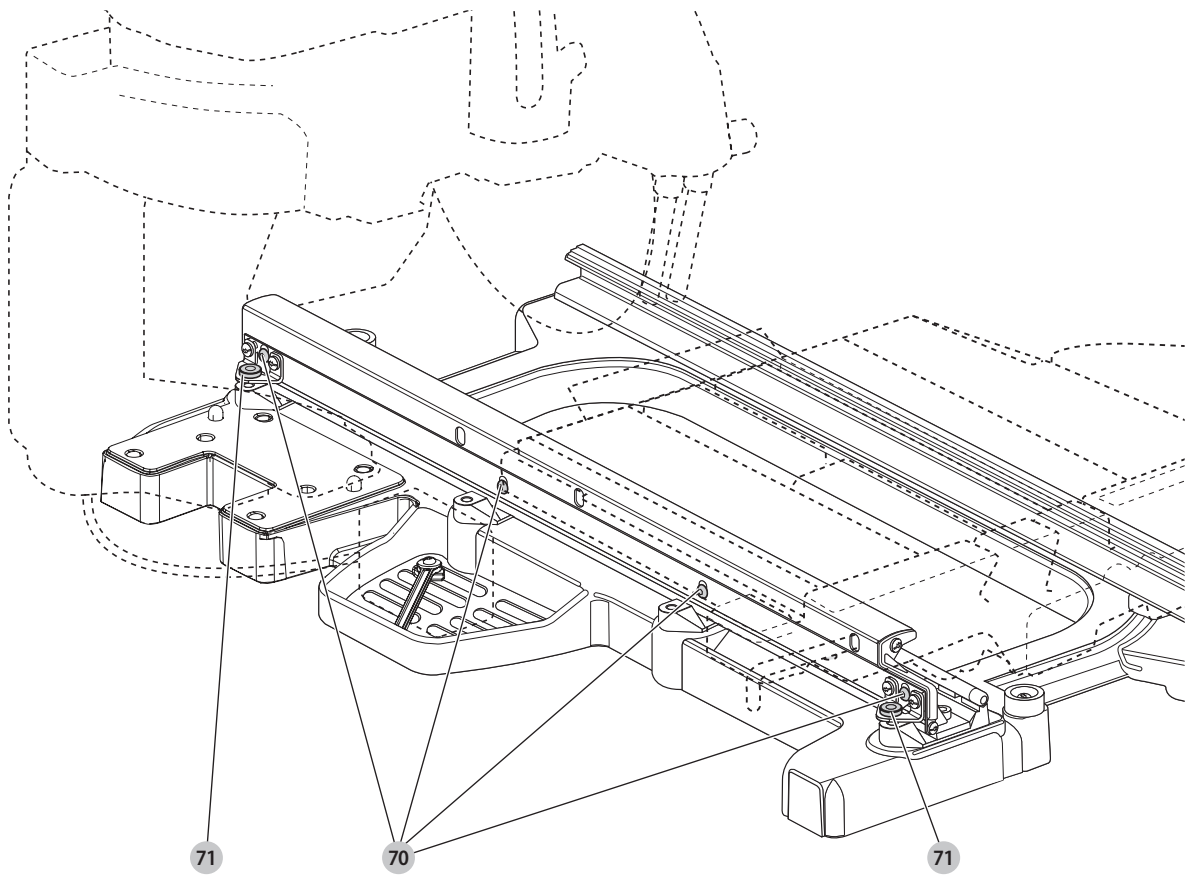

Fig.W



TILE SAW

D24000

Congratulations!

You have chosen a DEWALT tool. Years of experience, thorough product development and innovation make DEWALT one of the most reliable partners for professional power tool users.

Technical Data

		D24000
Voltage	V _{AC}	230
UK & Ireland (GB/ LX)	V _{AC}	230/115
Type		20
Power input (QS, GB/ LX)	W	1600/1500
No-load speed	min ⁻¹	4200
Cutting disc diameter	mm	250
Cutting disc bore	mm	25.4
Cutting disc body thickness	mm	1.5
Type of cutting disc		straight, non-recessed (continuous rim)
Max. peripheral speed cutting disc	min ⁻¹	5000
Bevel settings	°	22.5/45
Max. ripping capacity	mm	610
Dimensions—in use without stand - (L x W x H)	mm	1270 x 892 x 580
Dimensions—in use with stand (in highest position) - (L x W x H)	mm	1270 x 892 x 1395
Dimensions—in transportation mode (saw) - (L x W x H)	mm	793 x 610 x 470
Dimensions—in transportation mode (water pans) - (L x W x H)	mm	895 x 689 x 116
Depth of cut at 90°	mm	80
Nominal weight (including cutting disc)	kg	36
Max. allowable weight (with cutting disc and water)	kg	51
Noise values and vibration values (tri-ax vector sum) according to EN62841-1, EN12418		
L _{PA} (emission sound pressure level)	dB(A)	91.8
L _{WA} (sound power level)	dB(A)	101.5
K (uncertainty for the given sound level)	dB(A)	2.5
Vibration emission value a _h =		
	m/s ²	4.0
Uncertainty K =		
	m/s ²	0.5

The vibration emission level given in this information sheet has been measured in accordance with a standardised test given in EN12418 and may be used to compare one tool with another. It may be used for a preliminary assessment of exposure.

WARNING: The declared vibration emission level represents the main applications of the tool. However if the tool is used for different applications, with different accessories or poorly maintained, the vibration emission may differ. This may significantly increase the exposure level over the total working period.

An estimation of the level of exposure to vibration should also take into account the times when the tool is switched off or when it is running but not actually doing the job. This may significantly reduce the exposure level over the total working period.

Identify additional safety measures to protect the operator from the effects of vibration such as: maintain the tool and the accessories, keep the hands warm, organisation of work patterns.

NOTE: This device is intended for the connection to a power supply system with maximum permissible system impedance Z_{max} of 0.30 Ω at the interface point (power service box) of user's supply.

The user has to ensure that this device is connected only to a power system which fulfils the requirement above. If necessary, the user can ask the public power supply company for the system impedance at the interface point.

EC-Declaration of Conformity

Machinery Directive



Tile Saw D24000

DEWALT declares that these products described under **Technical Data** are in compliance with: 2006/42/EC, EN62841-1:2015 + AC:2015, EN12418:2000 + A1:2009, EN ISO 12100:2010.

These products also comply with Directive 2014/30/EU and 2011/65/EU. For more information, please contact DEWALT at the following address or refer to the back of the manual.

The undersigned is responsible for compilation of the technical file and makes this declaration on behalf of DEWALT.

Markus Rompel
Vice President of Engineering, PTE-Europe
DEWALT, Richard-Klinger-Straße 11,
D-65510, Idstein, Germany
30.10.2020

Definitions: Safety Guidelines

The definitions below describe the level of severity for each signal word. Please read the manual and pay attention to these symbols.

- DANGER:** Indicates an imminently hazardous situation which, if not avoided, **will** result in **death or serious injury**.
- WARNING:** Indicates a potentially hazardous situation which, if not avoided, **could** result in **death or serious injury**.
- CAUTION:** Indicates a potentially hazardous situation which, if not avoided, **may** result in **minor or moderate injury**.
- NOTICE:** Indicates a practice **not related to personal injury** which, if not avoided, **may** result in **property damage**.
- Denotes risk of electric shock.
- Denotes risk of fire.

General Power Tool Safety Warnings

WARNING: Read all safety warnings, instructions, illustrations and specifications provided with this power tool. Failure to follow all instructions listed below may result in electric shock, fire and/or serious injury.

SAVE ALL WARNINGS AND INSTRUCTIONS FOR FUTURE REFERENCE.

The term "power tool" in the warnings refers to your mains-operated (corded) power tool or battery-operated (cordless) power tool.

1) Work Area Safety

- a) **Keep work area clean and well lit.** Cluttered or dark areas invite accidents.
- b) **Do not operate power tools in explosive atmospheres, such as in the presence of flammable liquids, gases or dust.** Power tools create sparks which may ignite the dust or fumes.
- c) **Keep children and bystanders away while operating a power tool.** Distractions can cause you to lose control.

2) Electrical Safety

- a) **Power tool plugs must match the outlet. Never modify the plug in any way. Do not use any adapter plugs with earthed (grounded) power tools.** Unmodified plugs and matching outlets will reduce risk of electric shock.
- b) **Avoid body contact with earthed or grounded surfaces such as pipes, radiators, ranges and refrigerators.** There is an increased risk of electric shock if your body is earthed or grounded.
- c) **Do not expose power tools to rain or wet conditions.** Water entering a power tool will increase the risk of electric shock.
- d) **Do not abuse the cord. Never use the cord for carrying, pulling or unplugging the power tool. Keep cord away from heat, oil, sharp edges or moving parts.** Damaged or entangled cords increase the risk of electric shock.
- e) **When operating a power tool outdoors, use an extension cord suitable for outdoor use.** Use of a cord suitable for outdoor use reduces the risk of electric shock.
- f) **If operating a power tool in a damp location is unavoidable, use a residual current device (RCD) protected supply.** Use of an RCD reduces the risk of electric shock.

3) Personal Safety

- a) **Stay alert, watch what you are doing and use common sense when operating a power tool. Do not use a power tool while you are tired or under the influence of drugs, alcohol or medication.** A moment of inattention while operating power tools may result in serious personal injury.
- b) **Use personal protective equipment. Always wear eye protection.** Protective equipment such as a dust mask, non-skid safety shoes, hard hat or hearing protection used for appropriate conditions will reduce personal injuries.
- c) **Prevent unintentional starting. Ensure the switch is in the off-position before connecting to power source and/or battery pack, picking up or carrying the tool.** Carrying power tools with your finger on the switch or energising power tools that have the switch on invites accidents.
- d) **Remove any adjusting key or wrench before turning the power tool on.** A wrench or a key left attached to a rotating part of the power tool may result in personal injury.
- e) **Do not overreach. Keep proper footing and balance at all times.** This enables better control of the power tool in unexpected situations.
- f) **Dress properly. Do not wear loose clothing or jewellery. Keep your hair and clothing away from moving parts.** Loose clothes, jewellery or long hair can be caught in moving parts.
- g) **If devices are provided for the connection of dust extraction and collection facilities, ensure these are connected and properly used.** Use of dust collection can reduce dust-related hazards.

- h) **Do not let familiarity gained from frequent use of tools allow you to become complacent and ignore tool safety principles.** A careless action can cause severe injury within a fraction of a second.

4) Power Tool Use and Care

- a) **Do not force the power tool. Use the correct power tool for your application.** The correct power tool will do the job better and safer at the rate for which it was designed.
- b) **Do not use the power tool if the switch does not turn it on and off.** Any power tool that cannot be controlled with the switch is dangerous and must be repaired.
- c) **Disconnect the plug from the power source and/or remove the battery pack, if detachable, from the power tool before making any adjustments, changing accessories, or storing power tools.** Such preventive safety measures reduce the risk of starting the power tool accidentally.
- d) **Store idle power tools out of the reach of children and do not allow persons unfamiliar with the power tool or these instructions to operate the power tool.** Power tools are dangerous in the hands of untrained users.
- e) **Maintain power tools and accessories. Check for misalignment or binding of moving parts, breakage of parts and any other condition that may affect the power tool's operation. If damaged, have the power tool repaired before use.** Many accidents are caused by poorly maintained power tools.
- f) **Keep cutting tools sharp and clean.** Properly maintained cutting tools with sharp cutting edges are less likely to bind and are easier to control.
- g) **Use the power tool, accessories and tool bits, etc. in accordance with these instructions, taking into account the working conditions and the work to be performed.** Use of the power tool for operations different from those intended could result in a hazardous situation.
- h) **Keep handles and grasping surfaces dry, clean and free from oil and grease.** Slippery handles and grasping surfaces do not allow for safe handling and control of the tool in unexpected situations.

5) Service

- a) **Have your power tool serviced by a qualified repair person using only identical replacement parts.** This will ensure that the safety of the power tool is maintained.

Safety Instructions

 **WARNING!** When using electric tools basic safety precautions should always be followed to reduce the risk of fire, electric shock and personal injury including the following.

 Read all these instructions before attempting to operate this product and save these instructions.

SAVE THIS MANUAL FOR FUTURE REFERENCE.

Additional Safety Rules for Tile Saws

-  **WARNING:** Do not connect to the mains power supply into the unit until complete instructions are read and understood.
- **DO NOT OPERATE THIS MACHINE UNTIL IT IS COMPLETELY ASSEMBLED AND INSTALLED ACCORDING TO THE INSTRUCTIONS.** A machine incorrectly assembled can cause serious injury.
 - **DO NOT OPERATE THIS MACHINE IF THE CUTTING DISK GUARD IS NOT MOUNTED CORRECTLY OR IS DEFECTIVE.**
 - **TIGHTEN ALL CLAMP HANDLES, KNOBS AND LEVERS PRIOR TO OPERATION.** Loose clamps can cause parts or the workpiece to be thrown at high speeds.
 - **OBTAIN ADVICE FROM YOUR SUPERVISOR, INSTRUCTOR, OR ANOTHER QUALIFIED PERSON IF YOU ARE NOT THOROUGHLY FAMILIAR WITH THE OPERATION OF THIS MACHINE.** Knowledge is safety.
 - **MAKE CERTAIN THE BLADE ROTATES IN THE CORRECT DIRECTION.** See marking at the guard
 - **BE SURE ALL BLADE AND BLADE CLAMPS ARE CLEAN, RECESSED SIDES OF BLADE CLAMPS ARE AGAINST BLADE AND ARBOUR SCREW IS TIGHTENED SECURELY.** Loose or improper blade clamping may result in damage to the saw and possible personal injury.
 - **DO NOT OPERATE ON ANYTHING OTHER THAN THE DESIGNATED VOLTAGE FOR THE SAW.** Overheating, damage to the tool and personal injury may occur.
 - **DO NOT WEDGE ANYTHING AGAINST THE FAN TO HOLD THE MOTOR SHAFT.** Damage to tool and possible personal injury may occur.
 - **NEVER CUT METALS.** This can cause the carbide tips to fly off the blade at high speeds causing serious injury.
 - **NEVER HAVE ANY PART OF YOUR BODY IN LINE WITH THE PATH OF THE SAW BLADE.** Personal injury will occur.
 - **DO NOT PLACE EITHER HAND IN THE BLADE AREA WHEN THE SAW IS CONNECTED TO THE POWER SOURCE.** Inadvertent blade activation may result in serious injury.
 - **NEVER REACH AROUND OR BEHIND THE SAW BLADE.** A blade can cause serious injury.
 - **SECURE THE MACHINE TO A STABLE SUPPORTING SURFACE.** Vibration can possibly cause the machine to slide, walk, or tip over, causing serious injury.
 - **USE ONLY BLADES OF THE CORRECT SIZE AND TYPE SPECIFIED FOR THIS TOOL TO PREVENT DAMAGE TO THE MACHINE AND/OR SERIOUS INJURY.**
 - **THE MAXIMUM SPEED OF THE SAW BLADE SHALL ALWAYS BE GREATER THAN OR AT LEAST EQUAL TO THE SPEED MARKED ON THE RATING PLATE OF THE TOOL.**
 - **THE SAW BLADE DIAMETER MUST BE IN ACCORDANCE WITH THE MARKINGS ON RATING PLATE OF THE TOOL.**
 - **INSPECT BLADE FOR CRACKS OR OTHER DAMAGE PRIOR TO OPERATION.** A cracked or damaged blade can come apart and pieces can be thrown at high speeds, causing serious

injury. Replace cracked or damaged blades immediately. Observe the maximum speed marked on the saw blade.

- **DO NOT USE WARPED BLADES.** Check to see if the blade runs true and is free from vibration. A vibrating blade can cause damage to the machine and/or serious injury.
- **KEEP GUARD IN PLACE AND IN WORKING ORDER.** Do not operate this machine without guards in place
- **USE ONLY BLADE CLAMPS SPECIFIED FOR THIS TOOL TO PREVENT DAMAGE TO THE MACHINE AND/OR SERIOUS INJURY.**
- **MAKE SURE TO USE THE CORRECT SAW BLADE FOR THE MATERIAL TO BE CUT.**
- **CLEAN THE MOTOR AIR SLOTS OF CHIPS AND SAWDUST.** Clogged motor air slots can cause the machine to overheat, damaging the machine and possibly causing a short which could cause serious injury.
- **NEVER STAND ON TOOL.** Serious injury could occur if the tool is tipped or if the cutting tool is unintentionally contacted.
- **NEVER CUT WORKPIECES THAT REQUIRE MANUAL ACTION CLOSER THAN 15 CM FROM THE ROTATING CUTTING DISC.**
- **DO NOT PERFORM ANY OPERATION FREEHAND.** Hold the workpiece firmly against the fence and the guide.
- **SWITCH OFF THE MACHINE AND WAIT FOR THE CUTTING DISC TO STOP BEFORE MOVING THE WORKPIECE OR CHANGING THE SETTINGS.** Reaching with your hand near the coasting blade is dangerous
- **NEVER PERFORM ANY CLEANING OR MAINTENANCE WORK** when the machine is still running and the head is not in the rest position. Reaching with your hand near the turning blade is dangerous
- **DO NOT CUT WORKPIECES REQUIRING A MAXIMUM DEPTH OF CUT EXCEEDING THAT OF THE CUTTING DISC.**
- **DO NOT PERFORM DRY CUTS.** Dry cutting not only results in damage to the machine, it will also increase exposure to harmful airborne dust.
- **DO NOT USE CUTTING DISCS FOR SIDE GRINDING.** This can cause the carbide tips to fly off the blade at high speeds causing serious injury.
- **ALWAYS STORE TILE SAW WELL-PROTECTED AND IN A DRY PLACE, OUT OF REACH OF CHILDREN.** To prevent damage to the machine and unintended use.
- **DO NOT MAKE ADJUSTMENTS OR PARTS SUBSTITUTIONS TO ALTER THE FACTORY SETTINGS.** Technical alterations should only be carried out by the manufacturer, in compliance with the applicable.
- **WEAR GLOVES DURING THE USE OF THE TILE SAW.** Sawed workpieces could have sharp edges.

 **WARNING!** Take care that the connections are dry before activating the circuit and plugging in the machine.

- Keep water clear off the electrical parts of the tool and away from persons in the working area.
- Replacement of supply cord shall always be carried out by the manufacturer or his service agent.

 **WARNING!** After voltage recovery, set ON/OFF switch to off before actuating RESET button of Portable Residual Current Device (PRCD).

- Ensure your installation is provided with suitable cut out of "B" characteristic according to HD384.

Residual Risks

In spite of the application of the relevant safety regulations and the implementation of safety devices, certain residual risks cannot be avoided. These are:

The following risks are inherent to the use of these machines:

- injuries caused by touching the rotating parts
- injuries caused by disruption of the cutting disc

These risks are most evident:

- within the range of operation
- within the range of the rotating machine parts

In spite of the application of the relevant safety regulations and the implementation of safety devices, certain residual risks cannot be avoided. These are:

- Impairment of hearing.
- Risk of accidents caused by the uncovered parts of the rotating cutting disc.
- Risk of injury when changing the cutting disc.
- Risk of squeezing fingers when opening the guards.

Electrical Safety

The electric motor has been designed for one voltage only. Always check that the power supply corresponds to the voltage on the rating plate.

 **WARNING:** 115 V units have to be operated via a fail-safe isolating transformer with an earth screen between the primary and secondary winding.

If the supply cord is damaged, it must be replaced only by DEWALT or an authorised service organisation.

Mains Plug Replacement (U.K. & Ireland Only)

If a new mains plug needs to be fitted:

- Safely dispose of the old plug.
- Connect the brown lead to the live terminal in the plug.
- Connect the blue lead to the neutral terminal.
- Connect the yellow/green lead to the earth terminal.

Follow the fitting instructions supplied with good quality plugs. Recommended fuse: 13 A.

WARNING: Never use a light socket.
Never connect the live (L) or neutral (N) wires to the earth pin marked E or \perp .

Fitting a Mains Plug to 115 V Units (U.K. and Ireland Only)

- The plug should be fitted by a competent person. If you are in doubt, contact an authorized DEWALT repair agent or a qualified electrician.
- The plug fitted should comply with BS EN 60309 (BS4343), 16 Amps, earthing contact position 4h.

Using an Extension Cable

If an extension cable is required, use an approved 3-core extension cable suitable for the power input of this tool (see **technical data**). The minimum conductor size is 1.5 mm²; the maximum length is 30 m.

When using a cable reel, always unwind the cable completely.

Portable Residual Current Device

The machine is equipped with a portable residual current device (PRCD), which protects the user against electric shock by interrupting the circuit when a leakage current of 10 mA or greater is detected.

WARNING: Never operate the machine without the PRCD in place. Do not use the machine if the PRCD does not function properly. For the PRCD to work, the machine must be connected to an earthed wall socket. Before using the tile saw, check the function of the PRCD, pressing the TEST button.

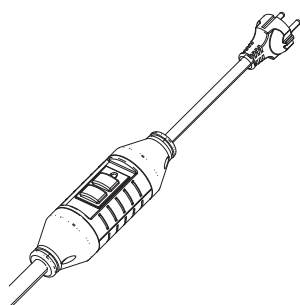

Package Contents

This package contains:

- 1 Motor frame assembly
- 1 Support frame assembly
- 1 Water basin
- 1 Water pump
- 1 Cutting disc
- 1 Sliding table
- 1 Extension table
- 1 Edge guide
- 1 Rear water collector
- 1 Sliding table water collector
- 4 Hex screws
- 1 Hex key
- 1 Instruction manual
- Check for damage to the tool, parts or accessories which may have occurred during transport.
- Take the time to thoroughly read and understand this manual prior to operation.

Labels on tool

The following pictographs are shown on the tool.



Read the instruction manual before use.



Do not use recessed cutting discs.



Wear safety goggles.



Always wear regular working gloves while operating this tool.



Always wear ear protection.



WARNING! Sharp edges.



On/off switch: position I (on) and 0 (off).



Carrying point



Do not place your hands within this area.



Max. depth of cut.



Bore diameter

Date Code (Fig. B1)

The date code **72**, which also includes the year of manufacture, is printed into the nameplate.

Example:

2020 XX XX
Year of Manufacture

Description (Fig. A1, A2)

WARNING: Never modify the power tool or any part of it. Damage or personal injury could result.

- 1 On/off switch
- 2 Depth adjustment knob
- 3 Operating handle
- 4 Sliding table
- 5 Edge guide
- 6 Extension table
- 7 Water nozzles
- 8 Cutting disc
- 9 Guard
- 10 Water basin
- 11 Depth stop
- 12 Bevel adjustment knob
- 13 Key storage
- 14 Sliding table water collector
- 15 Rear water collector

Intended Use

Your D24000 tile saw has been designed for professional wet tile cutting applications. Using the appropriate cutting disk, diameter 250 mm, it can cut concrete, brick, porcelain and ceramic materials. Providing optimum versatility, the machine performs the cutting operations of straight cutting (ripping), diagonal cutting, plunge cutting and bevel cutting easily, accurately and safely.

This machine is not to be used for any operation other than those mentioned in this manual.

DO NOT use under wet conditions or in the presence of flammable liquids or gases.

DO NOT let children come into contact with the tool. Supervision is required when inexperienced operators use this tool.

- Young children and the infirm.** This appliance is not intended for use by young children or infirm persons without supervision.
- This product is not intended for use by persons (including children) suffering from diminished physical, sensory or mental abilities; lack of experience, knowledge or skills unless they are supervised by a person responsible for their safety. Children should never be left alone with this product.

ASSEMBLY

WARNING: Prior to assembly always unplug the tool.

WARNING: When assembling the machine, always follow the instructions in the order as described below.

Unpacking the Machine and Its Parts

WARNING: When moving the machine, always seek assistance. The machine is too heavy for one person to handle.

- 1. Remove the loose packaging material from the box.
- 2. Lift the machine parts out of the box.
- 3. Remove any remaining packing material from the machine parts.

Mounting the Motor Frame to the Support Frame (Fig. B1)

- 1. Place the support frame **16** on a relatively smooth and level surface.
- 2. Place the motor frame **17** on the support frame aligning the holes in the foot **18** with the mounting holes **19**.
- 3. Insert a screw **20** into the holes.
- 4. Tighten the screws using the hex key **21** provided.

Mounting the Sliding Table to the Support Frame Assembly (Fig. B2, B3)

1. Make sure the pin lock **22** is in the unlock position.
2. Hold the table in front of the frame, aligning the rollers **23** with the roller rail **24**.
3. Place the rear roller onto the round rail.
4. Slide the table onto the rail, making sure that the bearings **25** locate in the slide rails **26**.
5. When the front of the table is approaching the frame, tilt the table slightly to clear the stop **27**.
6. Lock the table in position by rotating the pin lock **22** and pushing it into the hole **28** in the rail.

Placing the Machine Into the Water Basin (Fig. B1, B4)

1. Place the water basin **10** on a relatively smooth and level surface.
2. Fit the plug **29** into the drain hole.
3. Lift and hold the machine at the carrying points **73** as shown in Fig. B1.
4. Lower the machine into the water basin as shown.

Mounting the Extension Table (Fig. C)

1. Hold the extension table **6** in front of the right-hand side of the sliding table **4**.
2. Align the positioning pins **30** on the extension with the holes **31** in the sliding table.
3. Place the extension against the sliding table.
4. Tighten the clamp knob **32**.

Installing the Water Pump (Fig. D1, D2)

WARNING: Before installing the water pump into the basin, check if the supply cord is not damaged.

1. Install the fitting **34** onto the discharge, then attach the hose **33** to the fitting.
2. Place the water pump **35** in the deep corner of the water basin **10**.
3. Route the power cable and the water tube over the bottom of the water basin as to avoid them from getting caught up by the sliding table.
4. Turn the water flow valve to adjust the water flow (some pump models).

Mounting the Water Collectors (Fig. E1, E2)

Rear water collector (Fig. E1)

The rear water collector **15** collects water run-off when cutting large workpieces.

1. Hold the water collector in position to the rear of the water basin.
2. Slide the arms **36** underneath the edges **37** of the water basin until the recesses **38** locate behind the lugs.
3. Tilt the rear of the water collector slightly until the collector snaps in position.

Sliding table water collector (Fig. E2)

The sliding table water collector **14** travels with the table and collects water run-off from large tiles and diagonal cuts.

1. Hold the water collector in position to the right-hand side of the sliding table.
2. Slide the arms **39** underneath the edges **40** of the sliding table until the recesses **41** locate behind the lugs.
3. Tilt the rear of the water collector slightly until the collector snaps in position.

Mounting the Cutting Disc (Fig. F1–F3)

When mounting the saw blade, pay attention that the cutting direction (arrow direction on the cutting disc) corresponds with the direction of the arrow on the blade guard! The maximum diameter cutting disc that can be fitted is 254 mm.

Using the hex key **42** supplied, loosen the screw **43** on the side of the guard.

1. Pull back the rubber side flap **44** and lift the guard **9** towards the rear.
2. Depress the spindle lock button **45** with one hand, then take the supplied spanner **46** in the other hand to loosen the locking nut **47** by turning counterclockwise.

WARNING: To use the spindle lock, press the button as shown and rotate the spindle by hand until you feel the lock engage. Continue to hold the lock button in to keep the spindle from turning.

3. Remove the locking nut **47** and the outside flange collar **48**.
4. Install the cutting disc with the arrow facing the same way as the arrow on the guard.
5. Replace the outer flange collar **48**. Refer to **Material Thickness** for proper flange use.
6. Tighten the locking nut **47** by turning clockwise while holding the spindle lock engaged with your other hand.
7. Put the guard **9** back in position.
8. Tighten the screw **43** on the side of the guard.

WARNING: Never press the spindle lock while the cutting disc is rotating.

WARNING: To avoid the risk of injury, check that the guard is mounted correctly.

Material Thickness (Fig. F2)

- The D24000 is fitted with a large diameter flange **48**, recommended for cutting material up to 80 mm in depth.
- The larger flange should be used whenever possible to ensure optimum cutting performance.

Connecting the Machine to the Mains (Fig. A)

1. Make sure the on/off switch **1** is in the off position.
2. Connect the mains plug to a mains supply.
3. Press the PRCD reset button on the mains cord if the machine does not start.
4. Arrange a drip loop in the cord connecting the machine to mains to prevent water from dripping onto the plug. The drip loop is that part of the cord below the level of the socket.

ADJUSTMENT

WARNING: Prior to adjustment always unplug the tool.

WARNING: To reduce the risk of injury, always verify the blade is adjusted to the correct height and location in the centre of the cart groove before operating the saw.

Checking and Adjusting the Cutting Depth (Fig. G)

The rim of the cutting disc should always be at least 5 mm below the table surface.

1. Loosen the depth adjustment knob **2**.
2. Lower the arm to bring the cutting disc into its lowest position.
3. Tighten the depth adjustment knob **2**.
4. Make a dry run by pushing the table entirely through the cutting disc. **Check that the cutting disc does not foul the table.**
5. If adjustment is required, proceed as follows:
 - a. Loosen the depth adjustment knob **2**.
 - b. Loosen the wingnut **49** a few turns.
 - c. Adjust the cutting depth stop **11** as necessary, making sure that the rim of the cutting disc is at least 5 mm below the table surface.
 - d. Tighten the wingnut **49**.

Checking That the Crosscut Travel Is Perpendicular to the Fence (Fig. H1, H2)

1. Lower the arm to bring the cutting disc into its lowest position.
2. Move the table in front of the cutting disc.
3. Place a square **50** (not included with the tool) on the table and against the fence and just touching the cutting disc as shown.
4. Push the table through the cutting disc to check that the cutting disc traverses parallel to the square.
5. If adjustment is required, proceed as follows:
 - a. Slacken the screws **51** holding the rail assembly to the frame.
 - b. Move the rail manually.
 - c. With the square placed against the fence, check again that the cutting disc traverses parallel to the square and adjust as necessary.
 - d. Tighten the screws **51**.

Checking That the Cutting Disc Is Perpendicular to the Table (Fig. I1–I3)

1. Loosen the bevel adjustment knob **12**.
2. Press the saw head to the right to ensure it is fully vertical and tighten the bevel adjustment knob.
3. Lower the arm to bring the cutting disc into its lowest position.
4. Move the table until underneath the cutting disc.
5. Place a square **50** on the table and against the cutting disc as shown.
6. If adjustment is required, proceed as follows:
 - a. Loosen the bevel adjustment knob **12** and turn the vertical position adjustment stop screw **52** in or out until the cutting disc is at 90° to the table as measured with the square.
 - b. If the bevel pointer **53** does not indicate zero on the bevel scale **54**, loosen the screw **55** that secures the pointer and move the pointer as necessary.

Checking and Adjusting the Bevel Angle (Fig. I3, J)

1. Loosen the bevel adjustment knob **12** and move the saw head to the left. This is the 45° bevel position.
2. If adjustment is required, proceed as follows:
 - a. Turn the stopscrew **56** in or out as necessary until the pointer **53** indicates 45°.

Cutting a Kerf (Fig. K)

The kerf indicator **57** helps to locate the path of the cutting disc.

1. Switch on the machine and wait for the cutting disc to reach full speed.
2. Push the table entirely through the cutting disc to cut a kerf in the wheel **58**.
3. **Check that the cutting disc does not foul the table.**
4. Switch off the machine.
5. If the kerf is worn, a new kerf can be created.
 - a. Loosen the locking screw **59**.
 - b. Rotate the wheel **58** to expose uncut surface.
 - c. Tighten the locking screw **59**.
 - d. Cut a new kerf following the instructions as described above.

Locking the Sliding Table (Fig. B2, L)

The table can be locked in the following positions:

- Front position (cutting disc freely accessible) **60**.
 - Plunge position (cutting disc over middle of table) **61**.
 - Outfeed position (cutting disc at fence) **62**.
1. Move the table **4** to the desired position.
 2. Lock the table by rotating the pin lock **22** and pushing it into the hole in the rail.

Adjusting the Water Nozzles (Fig. A, B2, M)

The water nozzles **7** are adjustable to provide the necessary flow of cooling water.

- Adjust the nozzle by moving the handle **63** into the required position.
 - Maximum capacity (nozzles fully retracted) **64**.
 - Minimum overspray (nozzles in line with cutting disc) **65**.
 - Off position to eliminate water overspray between cuts and for replacing the cutting disc **66**.

INSTRUCTIONS FOR USE

Ensure the machine is placed to satisfy your ergonomic conditions in terms of table height and stability. The machine site shall be chosen so that the operator has a good overview and enough free surrounding space around the machine that allows handling of the workpiece without any restrictions.

To reduce effects of vibration make sure the environment temperature is not too cold, machine and accessory is well maintained and the workpiece size is suitable for this machine.

WARNING:

- Always observe the safety instructions and applicable regulations.
- Check that the machine has been set up securely.
- Check that the workpiece is properly supported.
- Make sure the cutting disc is not contacting the workpiece before the machine is switched on.
- Allow the motor to reach full speed before cutting.
- Apply only a gentle pressure to the machine. Do not force the cutting action.
- Keep your hands out of the path of the cutting disc. Do not place your hands within the marked area as shown in Figure N.

Prior to Operation

- Place the tile saw on a horizontal, stable, non-slip surface.
- Install the appropriate cutting disc.
- Make sure all locking knobs and clamp handles are tight.
- Fill the water basin with the sufficient amount of water for the water pump to be fully submerged.
- Use only clean water. No other liquid should be used.

Switching On and Off (Fig. O)

- To switch the machine on, set the on/off switch **1** to position I.
- To switch the machine off, set the on/off switch **1** to position 0.

Wired into the mains cable is the portable residual current device (PRCD) containing the no-volt release switch and the motor overload protector with manual reset. In case of a power shut-off, proceed as follows:

- Make sure the on/off switch **1** is in the off position.
- Press the reset button on the PRCD.

Locking the switch

- In order to avoid unauthorised use of the machine, lock the switch using a padlock.

Basic saw cuts

General Handling

- Try a few simple projects using scrap material until you develop a "feel" for the machine.
- Always make dry runs (without power) before finish cuts so that you can check the path of the cutting disc.

Vertical Straight Cross Cut (Fig. P)

1. Set the bevel angle to 0°.
2. Lower the arm to bring the cutting disc into a suitable position.
3. Place the workpiece flat on the table and against the fence, with the finished side up. Align the marking on the workpiece with the marking in the kerf indicator.
4. Keep both hands away from the path of the cutting disc.
5. Switch the machine on and allow the cutting disc to reach full speed. Wait until the cutting disc is completely covered with water.
6. Slowly feed the workpiece into the cutting disc, keeping it firmly pressed against the fence. Do not force. The cutting disc speed should be kept constant.
7. After completing the cut, switch the machine off, allow the cutting disc to stop and remove the workpiece.

Bevel Cross-Cut (Fig. Q)

Bevel angles can be set at 22.5° and 45°.

1. Loosen the bevel adjustment knob **12** and set the bevel as desired.
2. Tighten the bevel adjustment knob firmly.
3. Proceed as for a vertical straight cross-cut.

Diagonal Cut (Fig. A1, R1, R2)

The edge guide **5** allows cutting of angles at 45°.

1. Place the edge guide **5** with the mounting bracket **67** over the fence.
2. Flip the edge guide **5** into position for the required application:
 - Flip the edge guide to the right for cutting small pieces from large tiles.
 - Flip the edge guide to the left for any other application.
3. Set the edge guide to the required distance.
4. Tighten the knob **68** to secure the guide in place.
5. Proceed as for a vertical straight cross-cut.

Plunge Cut (Fig. S)

A plunge cut is used to remove the centre of a tile, e.g. for electrical outlets, drains, etc.

1. Mark the area to be cut on both sides of the tile.
2. Fit the appropriate size of cutting disc.
3. Adjust the cutting depth to allow the cutting disc to saw only halfway through the workpiece.
4. Place the workpiece flat on the table and against the fence, with the finished side up. Align the marking on the workpiece with the marking in the kerf indicator.
5. Switch the machine on and allow the cutting disc to reach full speed. Wait until the cutting disc is completely covered with water.
6. Move the table until the marking on the workpiece is underneath the cutting disc.
7. Lower the arm to feed the cutting disc into the workpiece. Do not overcut the mark. As soon as the marking has been cut, lock the arm into its highest position.
8. Repeat as for the other markings.
9. Turn the workpiece upside down. Proceed as described above for the second cuts to meet the first.
10. After completing the cut, switch the machine off, allow the cutting disc to stop and remove the workpiece.

Grooving (Fig. T)

A groove is made into a tile e.g. to accommodate hidden wiring.

1. Adjust the cutting depth as required.
2. Place the workpiece flat on the table and against the fence, with the down side up. Align the marking on the workpiece with the marking in the kerf indicator.
3. Proceed as for a vertical straight cross-cut.
4. Repeat the procedure to make a wider groove.

Optional Accessories

 **WARNING:** Since accessories, other than those offered by DeWALT, have not been tested with this product, use of such accessories with this tool could be hazardous. To reduce the risk of injury, only DeWALT recommended accessories should be used with this product.

Range of Cutting Discs Available

Type of cutting disc	Dimensions (diameter x bore)	Usage
DT3733	250 x 25,4 mm	Ceramic tile
DT3734	250 x 25,4 mm	Porcelain/stone tile
D240001		Leg stand

Consult your dealer for further information on the appropriate accessories.

Transporting (Fig. B1, U)

The detachable parts can be stored in the water basin for easy transportation.

1. Drain the water basin. See **Maintenance**.
2. Remove the edge guide and the extension table.
3. Lock the sliding table in position.
4. Remove the water collectors.
5. Lift the machine out of the water basin as shown.
6. Place the collectors into the water basin in the orientation as shown.
7. Turn the water basin upside down.
8. The edge guide and the extension table can be placed in the water pan before nested.
9. Lift and hold the machine at the carrying points **73** as shown in Fig. B1.

 **WARNING:** When carrying the machine, always seek assistance. The machine is too heavy for one person to handle. Always lock the sliding table before moving or transporting saw.

MAINTENANCE

Your DeWALT power tool has been designed to operate over a long period of time with a minimum of maintenance. Continuous satisfactory operation depends upon proper tool care and regular cleaning.

 **WARNING:** To reduce the risk of serious personal injury, turn tool off and disconnect tool from power source before making any adjustments or removing/installing attachments or accessories. Be sure the trigger switch is in the OFF position. An accidental start-up can cause injury.

 **WARNING:** To assure product SAFETY and RELIABILITY, repairs, maintenance and adjustment should be performed by a DeWALT factory service centre or a DeWALT authorized service centre. Always use identical replacement parts.

Draining the Water Basin (Fig. V)

1. The water basin must be drained after each use.
2. Place the water pump on the tray **69**.
3. Place a suitable container under the drain plug **29**.
4. Remove the drain plug.
5. Allow ample time for the liquid to drain.
6. After the liquid has been drained, re-install the drain plug.
7. Dispose of the liquid with due care for the environment.

Adjusting the Table Rolling Resistance (Fig. W)

To take out the clearance between the table and the rails, proceed as follows:

1. Loosen the rail height screws **70**.
2. Adjust the rail height adjusters **71** until the table moves smoothly.
3. Tighten the rail height screws.



Lubrication

Your power tool requires no additional lubrication.



Cleaning

WARNING: Blow dirt and dust out of the main housing with dry air as often as dirt is seen collecting in and around the air vents. Wear approved eye protection and approved dust mask when performing this procedure.

WARNING: Never use solvents or other harsh chemicals for cleaning the non-metallic parts of the tool. These chemicals may weaken the materials used in these parts. Use a cloth dampened only with water and mild soap. Never let any liquid get inside the tool; never immerse any part of the tool into a liquid.

Before use, carefully check the cutting disk guard to determine that it will operate properly. Ensure that mud, or work-piece particle cannot lead to blockage of one of the functions.

In case of workpiece fragments jammed between cutting disk and guard disconnect the machine from the power supply and follow the instructions given in section **Mounting the cutting disk**. Remove the jammed parts and reassembling the cutting disk.

Keep the ventilation slots clear and regularly clean the housing with a soft cloth.

The following cleaning operations must be performed every day.

1. Insert the water pump into a bucket of clean water and pump the water through the hose system.
2. Wipe the rails and support arm with a grout sponge or a rag.
3. Spray the water basin and the sliding table with clear water. Wipe any dust residue away with a grout sponge.

Storage

Store the equipment and accessories out of children's reach in a dark and dry place at above freezing temperature. The ideal storage temperature is between 5 °C and 30 °C.

Protecting the Environment



Separate collection. Products and batteries marked with this symbol must not be disposed of with normal household waste.

Products and batteries contain materials that can be recovered or recycled reducing the demand for raw materials. Please recycle electrical products and batteries according to local provisions. Further information is available at www.2helpU.com.

Belgique et Luxembourg België en Luxemburg	DEWALT – Belgium BVBA Egide Walschaertsstraat 16 2800 Mechelen	Tel: NL 32 15 47 37 63 Tel: FR 32 15 47 37 64 Fax: 32 15 47 37 99	www.dewalt.be enduser.BE@sbdinc.com
Danmark	DEWALT (STANLEY BLACK&DECKER AS) Roskildevej 22 2620 Albertslund	Tel: 70 20 15 10 Fax: 70 22 49 10	www.dewalt.dk kundeservice.dk@sbdinc.com
Deutschland	DEWALT Richard Klinger Str. 11 65510 Idstein	Tel: 06126-21-0 Fax: 06126-21-2770	www.dewalt.de infodwge@sbdinc.com
Ελλάς	DEWALT (Ελλάς) Α.Ε. ΕΔΡΑ-ΓΡΑΦΕΙΑ : Στρόβωνος 7 & Λ. Βουλιαγμένης, Πλυφάδα 166 74, Αθήνα SERVICE : Ημερος Τόπος 2 (Χάνι Αδάμ) – 193 00 Ασπρόπυργος	Τηλ: 00302108981616 Φαξ: 00302108983570	www.dewalt.gr Greece.Service@sbdinc.com
España	DEWALT Ibérica, S.C.A. Parc de Negocios "Mas Blau" Edificio Muntadas, c/Bergadá, 1, Of. A6 08820 El Prat de Llobregat (Barcelona)	Tel: 934 797 400 Fax: 934 797 419	www.dewalt.es respuesta.postventa@sbdinc.com
France	DEWALT (Stanley Black & Decker France SAS) 62 Chemin de la Bruyère CS 60105, 69574 DARDILLY Cedex	Tel: 04 72 20 39 20 Fax: 04 72 20 39 00	www.dewalt.fr scufr@sbdinc.com
Schweiz Suisse Svizzera	DEWALT In der Luberzen 42 8902 Urdorf	Tel: 044 - 755 60 70 Fax: 044 - 730 70 67	www.dewalt.ch service@rofoag.ch
Ireland	DEWALT Building 4500, Kinsale Road Cork Airport Business Park Cork, Ireland	Tel: 00353-2781800 Fax: 01278 1811	www.dewalt.ie Sales.ireland@sbdinc.com
Italia	DEWALT via Energypark 6 20871 Vimercate (MB), IT	Tel: 800-014353 39 039-9590200 Fax: 39 039-9590311	www.dewalt.it
Nederlands	DEWALT Netherlands BVPostbus 83, 6120 AB BORN	Tel: 31 164 283 063 Fax: 31 164 283 200	www.dewalt.nl
Norge	DEWALT Postboks 4613 0405 Oslo, Norge	Tel: 45 25 13 00 Fax: 45 25 08 00	www.dewalt.no kundeservice.no@sbdinc.com
Österreich	DEWALT Werkzeug Vertriebsges m.b.H Oberlaaerstrasse 248, A-1230 Wien	Tel: 01 - 66116 - 0 Fax: 01 - 66116 - 614	www.dewalt.at service.austria@sbdinc.com
Portugal	DEWALT Ed. D Dinis, Quina da Fonte Rua dos Malhoes 2 2A 2º Esq. Oeiras e S. Juliao da Barra, paço de Arcos e Caxias 2770 071 Paço de Arcos	Tel: +351 214667500 Fax: +351214667580	www.dewalt.pt resposta.posvenda@sbdinc.com
Suomi	DEWALT PL47 00521 Helsinki, Suomi	Puh: 010 400 4333 Faksi: 0800 411 340	www.dewalt.fi asiakaspalvelu.fi@sbdinc.com
Sverige	DEWALT BOX 94 43122 Mölndal Sverige	Tel: 031 68 61 60 Fax: 031 68 60 08	www.dewalt.se kundservice.se@sbdinc.com
Türkiye	Sanayi ve Ticaret Bakanlığı tebliğince kullanım ömrü 7 yıldır. Stanley Black & Decker Turkey Alet Üretim San. Tic. Ltd.Şti. AND Kozyatağı - İçerenköy Mah. Umut Sok. AND Ofis Sit. No: 10-12 / 82-83-84 Ataşehir/İstanbul, Türkiye	Tel: +90 216 665 2900 Faks: +90 216 665 2901	www.dewalt.com.tr support@dewalt.com.tr
United Kingdom	DEWALT, 210 Bath Road; Slough, Berks SL1 3YD	Tel: 01753-567055 Fax: 01753-572112	www.dewalt.co.uk emeaservice@sbdinc.com
Australia	DEWALT 810 Whitehorse Road Box Hill VIC 3128 Australia	Tel: Aust 1800 338 002 Tel: NZ 0800 339 258	www.dewalt.com.au www.dewalt.co.nz
Middle East Africa	DEWALT P.O. Box - 17164, Jebel Ali Free Zone (South), Dubai, UAE	Tel: 971 4 812 7400 Fax: 971 4 2822765	www.dewalt.ae support@dewalt.ae