

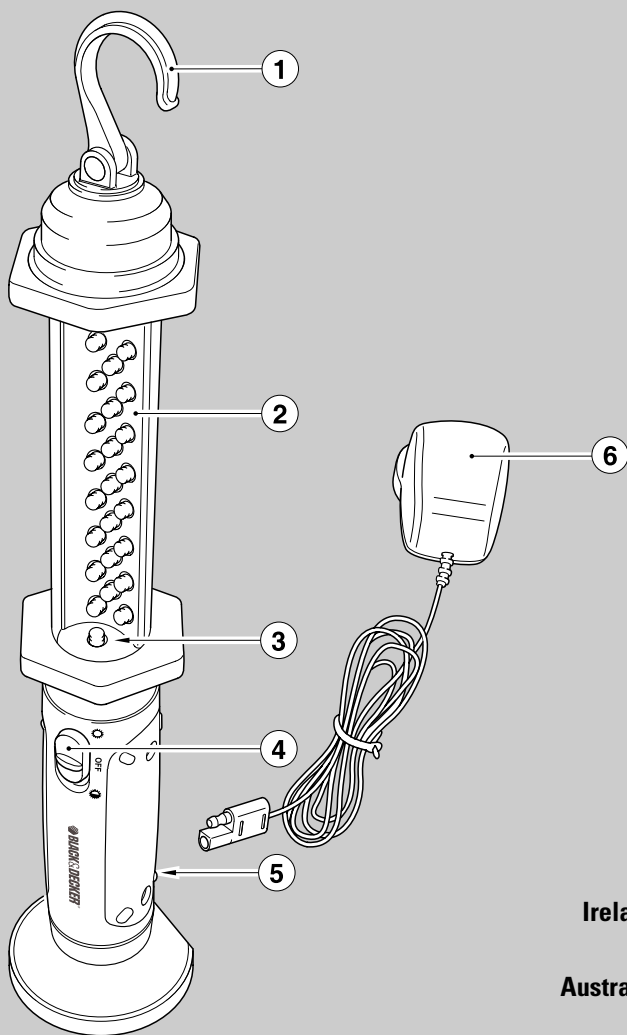

www.blackanddecker.co.uk



UK

Ireland

Australia

New Zealand

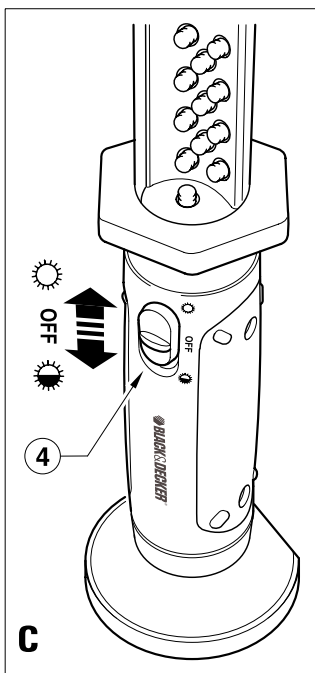
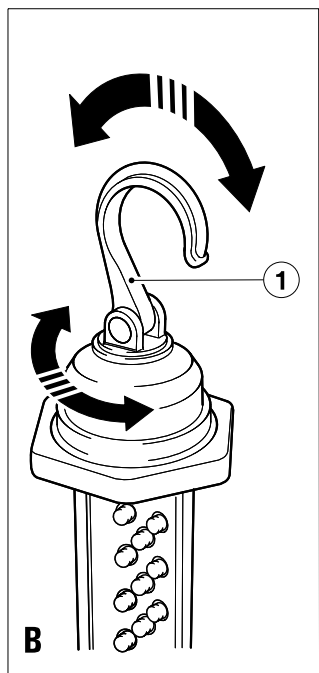
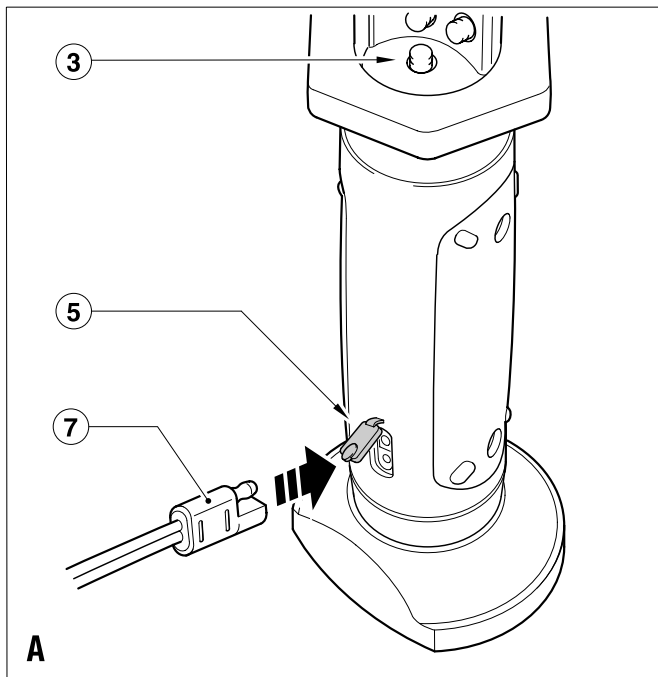

## Intended use

Your Black & Decker light bar has been designed for providing illumination for DIY projects and leisure use. This product is intended for consumer use only.

## Safety instructions

**Warning!** When using battery-powered appliances, basic safety precautions, including the following, should always be followed to reduce the risk of fire, leaking batteries, personal injury and material damage.

- ◆ Read all of this manual carefully before using the appliance.
- ◆ The intended use is described in this manual. The use of any accessory or attachment or the performance of any operation with this appliance other than those recommended in this instruction manual may present a risk of personal injury.
- ◆ Retain this manual for future reference.

## Using your appliance

Always take care when using the appliance.

- ◆ This appliance is not intended for use by young or infirm persons without supervision.
- ◆ The appliance is not to be used as a toy.
- ◆ Use in a dry location only. Do not allow the unit to become wet.
- ◆ Do not immerse the appliance in water.
- ◆ Do not open body casing. There are no user-serviceable parts inside.
- ◆ Do not operate the appliance in explosive atmospheres, such as in the presence of flammable liquids, gases or dust.
- ◆ To reduce the risk of damage to plugs and cords never pull the cable to remove the plug from a socket outlet.

## After use

- ◆ When not in use, the appliance should be stored in a dry, well ventilated place out of the reach of children.
- ◆ Children should not have access to stored appliances.

- ◆ When the appliance is stored or transported in a vehicle it should be placed in the boot or restrained to prevent movement following sudden changes in speed or direction.
- ◆ The appliance should be protected from direct sunlight, heat and moisture.

## Inspection and repairs

- ◆ Before use, check the appliance for damaged or defective parts. Check for breakage of parts, damage to switches and any other conditions that may affect its operation.
- ◆ Do not use the appliance if any part is damaged or defective.
- ◆ Have any damaged or defective parts repaired or replaced by an authorised repair agent.
- ◆ Never attempt to remove or replace any parts other than those specified in this manual.

## Specific safety instructions for light bars

- ◆ Inspect the lens for damage following impact or if the light bar is dropped. Do not operate without the lens in place or with a damaged lens.
- ◆ Never look directly into the light or shine the light into another person's eyes.
- ◆ Do not immerse light bar in water.
- ◆ Use only with the Black & Decker charging adapters that are provided with unit. Plug in the charging adapter at the light bar first, then plug into the charging source.

## Additional safety instructions for batteries and chargers

### Batteries

- ◆ Never attempt to open for any reason.
- ◆ Do not expose the battery to water.
- ◆ Do not store in locations where the temperature may exceed 40 °C.
- ◆ Charge only at ambient temperatures between 10 °C and 40 °C.
- ◆ Charge only using the chargers provided with the tool.

- ◆ When disposing of batteries, follow the instructions given in the section "Protecting the environment".
- ◆ Under extreme conditions, battery leakage may occur. When you notice liquid on the batteries, carefully wipe the liquid off using a cloth. Avoid skin contact.
- ◆ In case of skin or eye contact, follow the instructions below.

**Warning!** The battery fluid is a diluted sulphuric acid and may cause personal injury or damage to property. In case of skin contact, immediately rinse with water. If redness, pain or irritation occurs seek medical attention. In case of eye contact, rinse immediately with clean water and seek immediate medical attention.

## Chargers

Your charger has been designed for a specific voltage. Always check that the mains voltage corresponds to the voltage on the rating plate.

**Warning!** Never attempt to replace the charger unit with a regular mains plug.

Use your Black & Decker charger only to charge the battery in the tool with which it was supplied. Other batteries could burst, causing personal injury and damage.

- ◆ Never attempt to charge non-rechargeable batteries.
- ◆ Have defective cords replaced immediately.
- ◆ Do not expose the charger to water.
- ◆ Do not open the charger.
- ◆ Do not probe the charger.

The battery must be placed in a well ventilated area when charging.

### DO NOT OVERCHARGE:

- ◆ AC recharge up to 10 hours maximum.
- ◆ After recharge, disconnect the charging adaptor and wait 5 minutes before use.

### The following symbols are found on your charger:



Your charging base is double insulated; therefore no earth wire is required.



Fail-safe isolating transformer. The mains supply is electrically separated from the transformer output.



The charger automatically shuts off if the ambient temperature becomes too high. As a consequence the charger will be inoperable. The charging base must be disconnected from the mains supply and taken to an authorised service centre for repair.



The charging base is intended for indoor use only.

## Electrical safety



This tool is double insulated; therefore no earth wire is required. Always check that the power supply corresponds to the voltage on the rating plate.

- ◆ If the supply cord is damaged, it must be replaced by the manufacturer or an authorised Black & Decker Service Centre in order to avoid a hazard.

## Features

This appliance includes some or all of the following features:

1. Hook
2. LED light bar
3. Battery status LED
4. On/off/brightness switch
5. 12 Vdc charging socket
6. Mains charging adaptor

### Charging the light bar (fig. A)

- ◆ Make sure that the light bar is switched off (the on/off/brightness switch is in the OFF position).

**Warning!** Do not charge for longer than 10 hours.

- ◆ Insert the charger jack plug (7) into the 12 Vdc charging socket (5).
- ◆ Insert the mains charging adaptor (6) into a mains power socket.



- ◆ The red battery status LED (3) will illuminate to show that the product is charging (do not charge for more than 10 hours).

## Use

### Using the hook (fig. B)

- ◆ The hook (1) may be used to store or suspend the light bar. The hook rotates so that the light bar (1) can be set to any position. Make sure that the hook is secure around the supporting object.

### Operating the light bar (fig. C)

- ◆ To illuminate half of the LED's move the on/off/brightness switch (4) to the  position.
- ◆ To illuminate all of the LED's move the on/off/brightness switch (4) to the  position.
- ◆ To turn the unit off, move the on/off/brightness switch (4) to the OFF position.

## Maintenance

Your Black & Decker tool has been designed to operate over a long period of time with a minimum of maintenance.

Continuous satisfactory operation depends upon proper tool care and regular cleaning.

**Warning!** Before performing any maintenance or cleaning of the tool, unplug the unit from the power supply.

- ◆ From time to time wipe the tool with a damp cloth. Do not use any abrasive or solvent-based cleaner. Do not immerse the tool in water.

## Protecting the environment



Separate collection. This product must not be disposed of with normal household waste.

Should you find one day that your appliance needs replacement, or if it is of no further use to you, think of the protection of the environment. Black & Decker repair agents will accept old Black & Decker tools and ensure that they are

disposed of in an environmentally safe way.



Separate collection of used products and packaging allows materials to be recycled and used again. Re-use of recycled materials helps prevent environmental pollution and reduces the demand for raw materials.

Local regulations may provide for separate collection of electrical products from the household, at municipal waste sites or by the retailer when you purchase a new product.

Black & Decker provides a facility for the collection and recycling of Black & Decker products once they have reached the end of their working life. To take advantage of this service please return your product to any authorised repair agent who will collect them on our behalf.

You can check the location of your nearest authorised repair agent by contacting your local Black & Decker office at the address indicated in this manual. Alternatively, a list of authorised Black & Decker repair agents and full details of our after-sales service and contacts are available on the Internet at: [www.2helpU.com](http://www.2helpU.com).

## Technical data

BDBB26		
Input voltage	Vdc	12
Input current	mA	300 max
Weight	kg	0.46
Battery	Type	3.6V 1.5Ah SLA
<b>Charger</b>		
Input	Vac	230
Approx. charging time	h	10
Weight	kg	0.2

## EC declaration of conformity

BDBB26

Black & Decker declares that these products conform to:

Standards & Legislation.

2006/95/EC, 89/336/EEC, 95/54/EC,  
EN60335, EN61000, EN60598, EN61347,  
EN55014



Kevin Hewitt  
Director of Consumer Engineering  
Spennymoor, County Durham  
DL16 6JG,  
United Kingdom  
02-04-2007

- ◆ The product has been used for trade, professional or hire purposes.
- ◆ The product has been subjected to misuse or neglect.
- ◆ The product has sustained damage through foreign objects, substances or accidents.
- ◆ Repairs have been attempted by persons other than authorised repair agents or Black & Decker service staff.

To claim on the guarantee, you will need to submit proof of purchase to the seller or an authorised repair agent. You can check the location of your nearest authorised repair agent by contacting your local Black & Decker office at the address indicated in this manual. Alternatively, a list of authorised Black & Decker repair agents and full details of our after-sales service and contacts are available on the Internet at:

**[www.2helpU.com](http://www.2helpU.com)**

Please visit our website **[www.blackanddecker.co.uk](http://www.blackanddecker.co.uk)** to register your new Black & Decker product and to be kept up to date on new products and special offers. Further information on the Black & Decker brand and our range of products is available at **[www.blackanddecker.co.uk](http://www.blackanddecker.co.uk)**.

## Guarantee

Black & Decker is confident of the quality of its products and offers an outstanding guarantee. This guarantee statement is in addition to and in no way prejudices your statutory rights. The guarantee is valid within the territories of the Member States of the European Union and the European Free Trade Area.

If a Black & Decker product becomes defective due to faulty materials, workmanship or lack of conformity, within 24 months from the date of purchase, Black & Decker guarantees to replace defective parts, repair products subjected to fair wear and tear or replace such products to make sure of the minimum inconvenience to the customer unless:

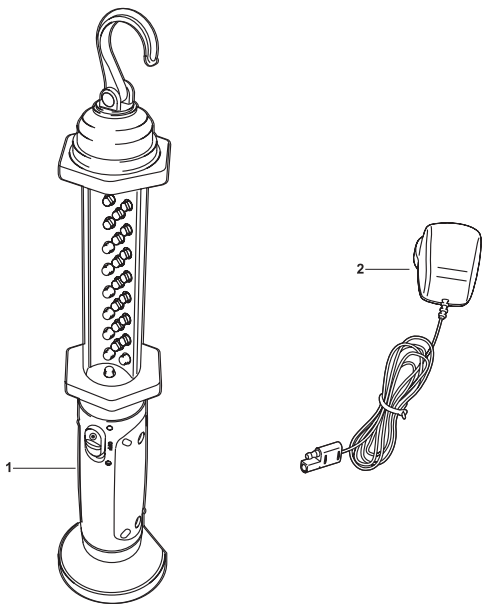

<b>Australia</b>	Black & Decker (Australia) Pty. Ltd. 20 Fletcher Road, Mooroolbark, Victoria, 3138	Tel. 03-8720 5100 Fax 03-9727 594065
<b>New Zealand</b>	Black & Decker 5 Te Apunga Place Mt Wellington Auckland 1060	Tel. +64 9 259 1133 Fax +64 9 259 1122
<b>United Kingdom</b>	Black & Decker 210 Bath Road Slough, Berkshire SL1 3YD	Tel. 01753 511234 Fax 01753 551155 Helpline 01753 574277