

Instruction Manual

1766 6" Bench Grinder

1788 8" Bench Grinder

- **EXTENSION CORDS.** Make sure your extension cord is in good condition. When using an extension cord, be sure to use one heavy enough to carry the current your product will draw. An undersized cord will cause a drop in line voltage resulting in loss of power and overheating. The following table shows the correct size to use depending on cord length and nameplate ampere rating. If in doubt, use the next heavier gage. The smaller the gage number, the heavier the cord.

		Minimum Gage for Cord Sets			
		Total Length of Cord in Feet			
Volts	120V	0-25	26-50	51-100	101-150
	240V	0-50	51-100	101-200	201-300
Ampere Rating	More Than	AWG			
	Not more Than				
0	-	6	18	16	16
6	-	10	18	16	16
10	-	12	16	16	14
12	-	16	14	14	12
					Not Recommended

- **OUTDOOR USE EXTENSION CORDS.** When tool is used outdoors, use only extension cords intended for use outdoors and so marked.
- **STAY ALERT.** Watch what you are doing. Use common sense. Do not operate tool when you are tired.
- **CHECK DAMAGED PARTS.** Before further use of the tool, a guard or other part that is damaged should be carefully checked to determine that it will operate properly and perform its intended function. Check for alignment of moving parts, binding of moving parts, breakage of parts, mounting, and any other conditions that may affect its operation. A guard or other part that is damaged should be properly repaired or replaced by an authorized service center unless otherwise indicated elsewhere in this instruction manual. Have defective switches replaced by authorized service center. Do not use tool if switch does not turn it on and off.

Additional Safety Instructions for Grinders

- Always use guards and eye shields. Always wear safety glasses or other eye protection when operating this tool and keep the eye shields mounted in their proper position on the wheel guard.
- Replace a cracked wheel immediately. Handle grinding wheels carefully to avoid bumping or dropping. **DO NOT** use a grinding wheel that has been dropped. Before using, inspect recommended accessory for cracks or flaws. If such a crack or flaw is evident, discard the accessory. The accessory should also be inspected whenever you think the tool may have been dropped.
- Before mounting a new wheel, be sure that it is marked with an RPM that is the same as, or higher than, the no-load speed of the grinder as marked on the nameplate. Keep tool rests and spark shields adjusted.
- Never start a grinder with anyone, including the operator, standing in line with the wheel. After installing a replacement wheel, stand to one side and allow it to revolve freely for about one minute.
- Do not grind on the sides of grinding wheels unless they are the special wheels designed specifically for this purpose.
- Do not overtighten wheel nut.
- Use only clamp washer furnished with this grinder.
- Bolt bench grinder to a bench or pedestal to prevent movement.
- **SEE PAGE 5 FOR BENCH MOUNTING INSTRUCTIONS.**
- Use accessories only in the proper and intended manner.

SAVE THESE INSTRUCTIONS

Motor

Your B&D tool is powered by a B&D built motor. Be sure your power supply agrees with the nameplate marking. Voltage decrease of more than 10% will cause loss of power and overheating. All B&D tools are factory tested; if this tool does not operate, check the power supply.

Switch

The switch is located on the front of the grinder near the bottom. To turn the tool on, depress the rocker switch near the word "ON". To turn the tool off, depress the rocker switch near the word "OFF".

Installing Tool Rests

TURN OFF TOOL AND DISCONNECT FROM POWER SUPPLY.

Your grinder includes a hex wrench, attached to the right of the On/Off switch. Use this wrench when installing the tool rest brackets, tool rests and eye shield brackets.

First install the tool rest brackets, as shown in Figure 1. Next attach the tool rests, as shown in Figure 1. Use the bolts, washers and spacers from the plastic bag to secure the brackets and tool rests in place.

NOTE: There is a left and a right tool rest. When in actual use, the tool rests should be adjusted to within 1/8" of the grinding wheel or other accessory being used.

Installing Spark Guards and Eye Shield Brackets

TURN OFF TOOL AND DISCONNECT FROM POWER SUPPLY.

The combination spark guard and eye shield brackets are assembled and in a plastic bag. They are identified L for left and R for right. Refer to Figure 2 to install them to the bench grinder using the two screws in the wheel guard (in some cases these screws will be in the plastic bag). Adjust the edge of the spark guard to within 1/16" of the grinding wheel or other accessory as shown in the figure. Tighten the two screws securely.

Figure 1

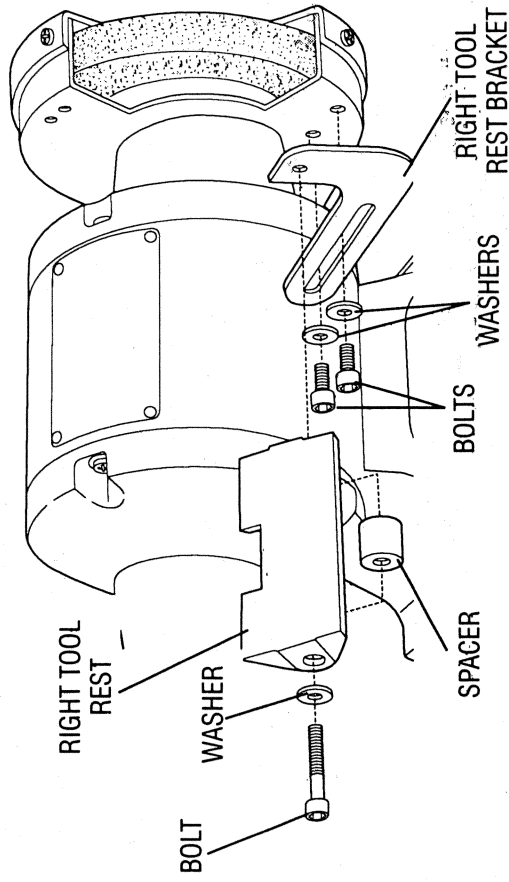
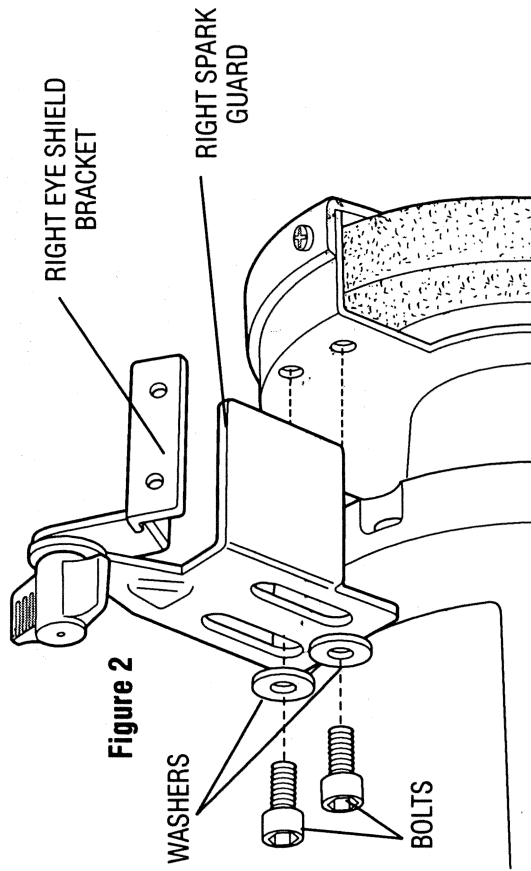

Figure 2



Installing Eye Shields

TURN OFF TOOL AND DISCONNECT FROM POWER SUPPLY.

Remove the steel strip from the top surface of each eye shield by removing the two screws. Install the shields, (they are identical and will fit either side) to the brackets, as shown in Figure 3. Tighten screws securely. Adjust eye shields so they are between the wheels and your eyes.

EYE SHIELDS ARE NOT DESIGNED TO REPLACE SAFETY GLASSES.

Tighten the shields in place by tightening the plastic knob in the bracket assembly. Remove protective paper cover.

Operating Instructions

To operate the grinder, put on safety glasses and turn the tool on. Allow it to reach full speed (3600 RPM for 1788, 3450 RPM for 1766) before grinding. Hold the workpiece firmly and against the tool rest. Hold very small pieces with pliers or other suitable clamps. Feed the work smoothly and evenly into the grinding wheel. Move the work slowly and avoid jamming the work against the wheel. As the wheel tends to slow down you should occasionally release the pressure to let the wheel return to full speed.

Grind only on face of the grinding wheel and never the side of it. (Some wheels are designed for side grinding and will say so on their blotters.)

CAUTION: Prolonged grinding will cause most materials to become hot. Use care when handling them.

Lubrication

Bench grinder spindles are mounted on ball bearings. No periodic lubrication is required.

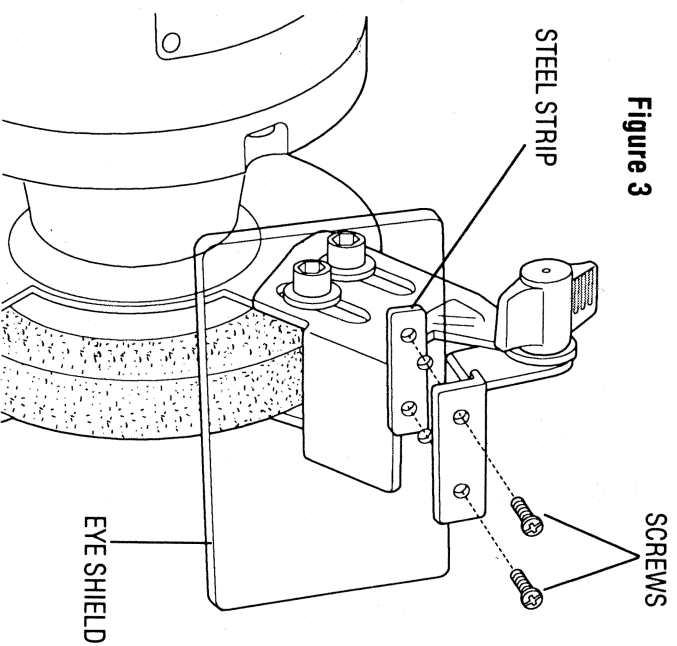

Figure 3

IMPORTANT!

To assure product safety and reliability, particularly for double insulated tools, repairs, maintenance and adjustment (excluding maintenance described in this manual) should be performed by B&D service centers or authorized service centers, using identical B&D replacement parts.

Bench Mounting

TURN OFF TOOL AND DISCONNECT FROM POWER SUPPLY.

Mounting the grinder securely to a bench is strongly recommended in order to prevent movement of the grinder when pressure is applied against a

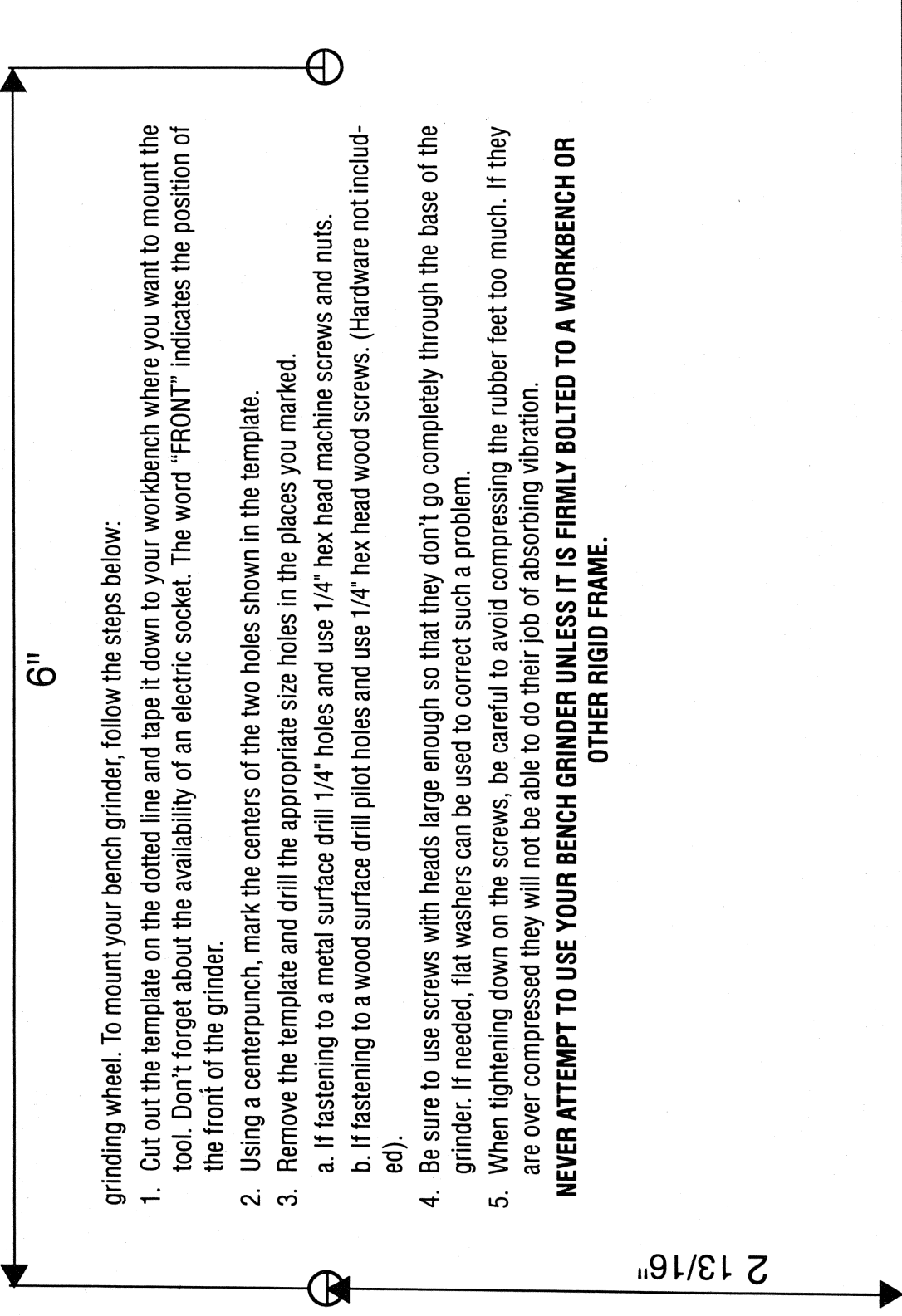

grinding wheel. To mount your bench grinder, follow the steps below:

1. Cut out the template on the dotted line and tape it down to your workbench where you want to mount the tool. Don't forget about the availability of an electric socket. The word "FRONT" indicates the position of the front of the grinder.
2. Using a centerpunch, mark the centers of the two holes shown in the template.
3. Remove the template and drill the appropriate size holes in the places you marked.
 - a. If fastening to a metal surface drill 1/4" holes and use 1/4" hex head machine screws and nuts.
 - b. If fastening to a wood surface drill pilot holes and use 1/4" hex head wood screws. (Hardware not included).
4. Be sure to use screws with heads large enough so that they don't go completely through the base of the grinder. If needed, flat washers can be used to correct such a problem.
5. When tightening down on the screws, be careful to avoid compressing the rubber feet too much. If they are over compressed they will not be able to do their job of absorbing vibration.

NEVER ATTEMPT TO USE YOUR BENCH GRINDER UNLESS IT IS FIRMLY BOLTED TO A WORKBENCH OR OTHER RIGID FRAME.

CUT ALONG THIS LINE

FRONT

Changing Accessories

TURN OFF TOOL AND DISCONNECT FROM POWER SUPPLY.

CHANGE ACCESSORIES WHEN THE SPARK GUARD CAN NO LONGER BE ADJUSTED TO 1/16" FROM THE WHEEL.

(For 1766: USE ONLY WHEELS THAT MEASURE 6" IN DIAMETER. THIS TOOL HAS 1/2" ARBORS ON BOTH SIDES)

(For 1788: USE ONLY WHEELS THAT MEASURE 8" IN DIAMETER. THIS TOOL HAS 5/8" ARBORS ON BOTH SIDES.)

Follow the steps below to remove the replace an accessory.

1. Raise the eye shield up, out of the way.
2. Loosen and pull the tool rest out as far as possible. Do not remove it.
3. Loosen and pull the spark guard out as far as possible. Do not remove it.
4. Remove the screws from the wheel cover and remove cover.
5. Using hex or adjustable wrenches of the appropriate sizes, grasp the two hex nuts holding the wheels to the arbor shaft at each end of the tool. To remove the wheel from the right side of the tool, turn the right side hex nut counterclockwise. While holding the left side hex nut stationary. To remove the wheel from the left, turn the left side hex nut clockwise while holding the right side hex nut stationary.
6. Remove the wheel washer and the wheel.
7. Inspect the wheel for cracks, chips or any other visible damage (other than normal wear) and discard if such damage is found. Inspect the blotter for damage. If the blotter is missing or severely damaged, replace it with a piece of thin cardboard or blotter paper cut in the same shape.
NEVER USE A WHEEL WITHOUT A BLOTTER.
8. Install the new wheel or other accessory. Be sure that both wheel washers are in place (concave sides toward wheel). See Figure 4. (for 1766 see Figures 4 and 5).

9. Hold as before and tighten the nut firmly but do not overtighten. Overtightening can crack a grinding wheel.
10. Replace the wheel cover and its screws.
11. Adjust the spark guard to 1/16" from the wheel and tighten it securely.
12. Adjust the tool rest to 1/8" from the wheel and tighten securely.
13. Adjust the eye shield to a point between your eyes and the wheel. The bench grinder is now ready to use.
14. Follow the above steps to install buffing wheels and wire wheel brushes as well as grinding wheels.

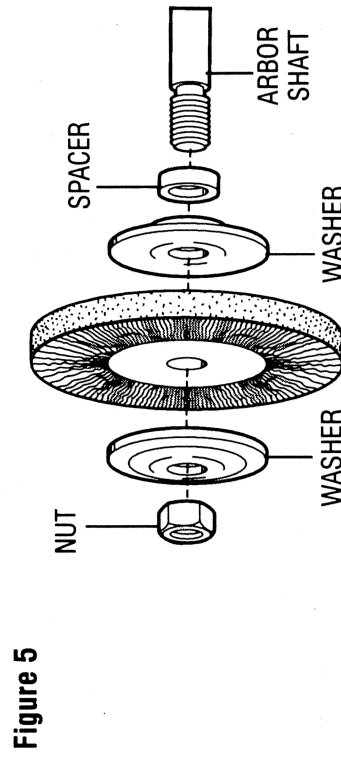
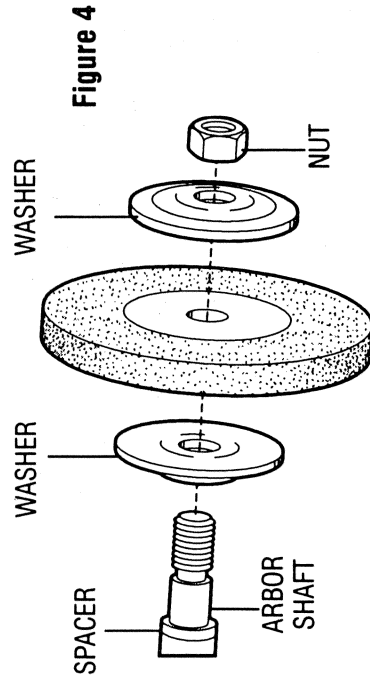

Accessories

Recommended accessories for use with your tool are available at extra cost from your distributor or local service center.

⚠ CAUTION: The use of any non-recommended accessory may be hazardous.

If you need assistance in locating any accessory call **1-800-9-BD TOOL:** (1-800-923-8665) or contact Black & Decker (U.S.) Inc., Consumer Services Department, 626 Hanover Pike, P.O. Box 618, Hampstead, MD 21074.

1766

GRINDING WHEELS

5/8" Face, 6" dia. 60 grit medium grinding wheel
3/4" Face, 6" dia. 60 grit medium grinding wheel
5.8" Face, 6" dia. 36 grit coarse grinding wheel
1/2" Face, 6" dia. 60 grit medium grinding wheel

MAX. SAFE SPEED

4136 RPM
4136 RPM
4136 RPM
3825 RPM

BUFFING WHEELS

5/8" Face, 6" dia. cotton buffing wheel

3600 RPM

WIRE WHEEL BRUSHES

1/2" arbor, 5/8" Face, 6" dia.

3600 RPM

1788

GRINDING WHEELS

7/8" & 1" Face, 8" dia. 60 grit medium grinding wheel
7/8" & 1" Face, 8" dia. 36 grit coarse grinding wheel

MAX. SAFE SPEED

3600 RPM
3600 RPM

BUFFING WHEEL

5/8" arbor, 8" dia. cotton buffing wheel

3600 RPM

WIRE WHEEL BRUSHES

5/8" arbor, 5/8" - 1 1/4" Face, 8" dia.

3600 RPM

Every B&D tool is of the highest quality.

If you wish to contact us regarding this product, please call toll free between 8:00am and 8:00pm ET, seven days a week:

1-800-9-BD TOOL

(1-800-923-8665)

One Year Free Maintenance

All B&D tools for Industry and Construction are covered under a one year free maintenance program where B&D will inspect your tool for safety and provide necessary maintenance or repairs, including normal wear and tear parts, for one year, FREE OF CHARGE.

Full Warranty

All B&D tools for Industry and Construction are warranted to be free of any defects in materials or workmanship. Upon thorough examination of tool, B&D will repair or replace, at our option, any product that is determined to be defective.

Conditions

The service/safety check and the warranty do not apply to: repairs made or attempted by anyone other than an authorized B&D service location; misuse, abuse, neglect, improper application of the tool; missing parts; or normal wear and tear (after first year of ownership). Please return the complete unit, transportation prepaid, to any B&D factory owned or B&D authorized service center location (list provided with tool or see Yellow Pages under "Tools Electric").

Black & Decker (U.S.) Inc. • 701 East Joppa Road, Towson, Maryland 21286

Printed in Taiwan (NOV96-1) Form No. 383362 Copyright © 1996